

Response Marine # 630 (Falmouth 20' Rescue): Drawing List

7/16/24

(in page order of pdf file)

<u>DWG #</u>	<u>Title</u>	<u>Date</u>
630 -1-1	Deck Plan- Shaded	7/16/24
-1-2	Inboard Profile- Shaded	7/16/24
-1-3	End Views	7/16/24
-1-4	Port Perspective	7/16/24
-1-5	Stern Qtr. Perspective	7/16/24
-1-6	Bow Qtr. Perspective	7/16/24
-2-1A	Frame Locations	7/16/24
-2-1B	Sheer Widths	7/16/24
-2-2	Keel Layout	7/16/24
-2-3	Girder Layout	7/16/24
-2-4	Bottom Structure	7/16/24
-2-5	Topsides Structure	7/16/24
-2-6	Conduits	7/16/24
-2-7A	Transom	7/16/24
-2-8	Side Decks	7/16/24
-2-9	Side Deck Coamings	7/16/24
-2-10	Weather Decks	7/16/24
-2-11A	Dive Door	7/16/24
-2-11B	Dive Door, TS Plate Marks	7/16/24
-2-11C	Transom Bhd Perspective	7/16/24
-2-12	Engine Bracket	7/16/24
-2-13	Bottom Doublor	7/16/24
-3-1	Fuel Tank, 100 gal, gross	7/16/24
-4-1	Console- Fwd Perspective	7/16/24
-7-1	Stowage Hatches	7/16/24
-7-2A	Transom Bench	7/16/24
-7-2B	Transom Bench Details	7/16/24
-B-1	"B-1" Flange Forming	7/16/24
-F-1	Frame 1	7/16/24
-F-2	Frame 2, WTBHD	7/16/24
-F-3	Frame 3	7/16/24
-F-3D	Frame 3, Dimensions	7/16/24
-F-4	Frame 4	7/16/24
-F-4D	Frame 4, Dimensions	7/16/24
-F-41	Frame 41 & 43	7/16/24
-F-42	Frame 42	7/16/24
-F-5	Frame 5, WTBHD	7/16/24
-F-5D	Frame 5, Dimensions	7/16/24
-F-6	Frame 6	7/16/24

Response Marine, Inc.

NC Parts for #630, Falmouth 20' Rescue
File: RMI\des\Viking\Deriv\559 WMW\Deriv\630\
Revised: 7/18/24

Print Date: 7/18/24

1/8" 5052 Parts

<u>Part #</u>	<u>Pieces</u>	<u>Description</u>	<u>Bending Info</u>
LP-3	1	Leaning Post, Shelf	
HS-TBHD	1	Hinged Seat Flat, at Tran Bhd	(6) R 1/8"
ST-P	1	Scupper Tube, Port. Tbhhd to Tran	R 1/8"
ST-S	1	Scupper Tube, Stbd, Tbhhd to Tran	R 1/8"
	4	Total Pieces (1/8", 5052)	

3/16" 5052 Parts

<u>Part #</u>	<u>Pieces</u>	<u>Description</u>	<u>Bending Info</u>
CON-A	1	Console, Back, Dash, & Top	(2) R 1/8"
CON-B	1	Console Front	R 1/8"
CON-B-SP	1	Console Front Soft Patch	
CON-CP	1	Console Side, Port	R 1/8"
CON-CS	1	Console Side, Stbd	R 1/8"
CON-D	1	Console Fwd Seat Face	(2) R 1/8"
CON-HS	1	Console Seat Hatch Lid	(5) R 1/8"
H-CON	2	Hatch Lids, Console Sides	(4) R 1/8"
H-F1	1	Hatch Lid, Frame 1	(4) R 1/8"
H-TB1	1	Hatch Lid, Transom Bhd, Center	(4) R 1/8"
H-TB2	1	Hatch Lid, Transom Bhd, Port	(4) R 1/8"
LP-1	1	Leaning Post, Sides & Back	(4) R 1/8"
LP-2	1	Leaning Post, Front & Top	Bump
T-A	1	Fuel Tank Body	(4) R 1/8"
T-BL	1	Fuel Tank, Long'l Baffle	
T-BT	1	Fuel Tank, Transverse Baffle	
T-C	2	Fuel Tank Ends	
T-D	1	Fuel Tank Top	
	20	Total Pieces (3/16" 5052)	

3/16" 5086 Parts

<u>Part #</u>	<u>Pieces</u>	<u>Description</u>	<u>Bending Info</u>
ALB	1	Anchor Locker Bottom	
CON-B-SPR	1	Console Front Soft Patch RING	
D-A	1	Deck Body, F1-F2	
D-BP	1	Deck Body, F2-F4, Port	
D-BS	1	Deck Body, F2-F4, Stbd	
D-CP	1	Deck Body, F4-FTran, Port	
D-CS	1	Deck Body, F4-FTran, Stbd	
D-D	1	Deck Body, Engine Deck, Ftran-Transom	
D-SP	2	Deck Soft Patches, PROUD, inside Console	
DD-DT	1	Dive Door, Door Bottom	Flange B-1
DD-FA	1	Dive Door Frame, Fwd	Flange B-1
DD-FB	1	Dive Door Frame, Aft	Flange B-1, 80°
DD-HFB	1	Dive Door Hull Frame, Aft	Flange B-1, 80°
DD-HT	1	Dive Door, Hull Threshold	Flange B-1
DM-P	1	Deck Margin, F3-Transom, Port	
DM-S	1	Deck Margin, F3-Transom, Stbd	
F1	1	Frame 1	
F2	1	Frame 2	Flange B-1
F2-P	1	Frame 2, Stbd (Gunwale to TSL-A)	
F2-S	1	Frame 2, Port (Gunwale to TSL-A)	
F3	1	Frame 3	Flange B-1
F3-P	1	Frame 3, Port	Flange B-1
F3-S	1	Frame 3, Stbd	Flange B-1
F4	1	Frame 4	Flange B-1
F41	1	Frame 41, Between Girders	
F42	1	Frame 42	Flange B-1
F42-P	1	Frame 42, Port (Gunwale to TSL-B)	
F42-S	1	Frame 42, Stbd (Gunwale to TSL-B)	
F43	1	Frame 43, Between Girders	
F4-P	1	Frame 4, Port	Flange B-1
F4-S	1	Frame 4, Stbd	Flange B-1
F5	1	Frame 5	Flange B-1
F5-P	1	Frame 5, Port	Flange B-1
F5-S	1	Frame 5, Stbd	Flange B-1
F6	1	Frame 6	Flange B-1
FD	1	Foredeck	
FDC	1	Foredeck Coaming	
FTR	1	False Transom	R 3/8"
G-P	1	Girder, Tran-F4, Port	Flange B-1

G-S	1	Girder, Tran-F4, Stbd	Flange B-1
SDC-AP	1	Side Deck Coaming, Fwd Port	
SDC-AS	1	Side Deck Coaming, Fwd Stbd	
SDC-BP	1	Side Deck Coaming, Jog Port	
SDC-BS	1	Side Deck Coaming, Jog Stbd	
SDC-CP	1	Side Deck Coaming, Aft Port	
SDC-CS	1	Side Deck Coaming, Aft Stbd (Incl. Tdoor Liner)	
SD-P	1	Side Deck, Port	
SD-S	1	Side Deck, Stbd	
STEM	1	Stem Flat	
TBHD	1	Transom Bhd	
TD	1	Transom Deck	
TD-1	1	Transom Doorway, Inboard Side	
TD-2	1	Transom Doorway, Threshold	
TS-CP	1	Topsides Coaming Lip Aft, Port	90°, R 3/8"
TS-CS	1	Topsides, Coaming Lip Aft, Stbd	90°, R 3/8"
TSL-BP	1	Topside Stringer, F4-F5, Port	Flange B-1
TSL-BS	1	Topside Stringer, F4-False Tran, Stbd	Flange B-1
TSL-CP	1	Topside Stringer, F5-False Tran, Port	
TS-P	1	Topsides, Port	
TS-S	1	Topsides, Stbd	
	61	Total Pieces (3/16" 5086)	

1/4" 5086 Parts

<u>Part #</u>	<u>Pieces</u>	<u>Description</u>
B-P	1	Bottom Plate, Port
B-S	1	Bottom Plate, Stbd
BD	2	Bottom Doublers at Forefoot
BS1-P	1	Bottom Longitudinal 1, Port
BS1-S	1	Bottom Longitudinal 1, Stbd
BS2-P	1	Bottom Longitudinal 2, Fwd, Port
BS2-S	1	Bottom Longitudinal 2, Fwd, Stbd
BS3-P	1	Bottom Longitudinal 3, Port
BS3-S	1	Bottom Longitudinal 3, Stbd
C-P	1	Chine, Port
C-S	1	Chine, Stbd
EB-2D	1	Engine Bracket, Deck Doubler
EB-4	2	Engine Bracket, Bottom Gussets
FTRS	1	False Transom Stiffener
TRAN	1	Transom
TRS	1	Transom Stiffener, Transverse

TS-CTP	1	Topsides Coaming Cap at Transom, Port
TS-CTS	1	Topsides, Coaming Cap at Transom, Stbd
TSL-AP	1	Topside Stringer, Fwd Port, Stem to F4
TSL-AS	1	Topside Stringer, Fwd Stbd Stem to F4
	22	Total Pieces (1/4")

3/8" 5086 Parts

<u>Part #</u>	<u>Pieces</u>	<u>Description</u>
EB-1	1	Engine Bracket, Transom
EB-2	2	Engine Bracket, Sides
EB-3	1	Engine Bracket, Lip
K-A	1	Keel, Fwd
K-B	1	Keel, Mid
K-C	1	Keel, Aft
	7	Total Pieces (3/8")

114 Total Cut Parts

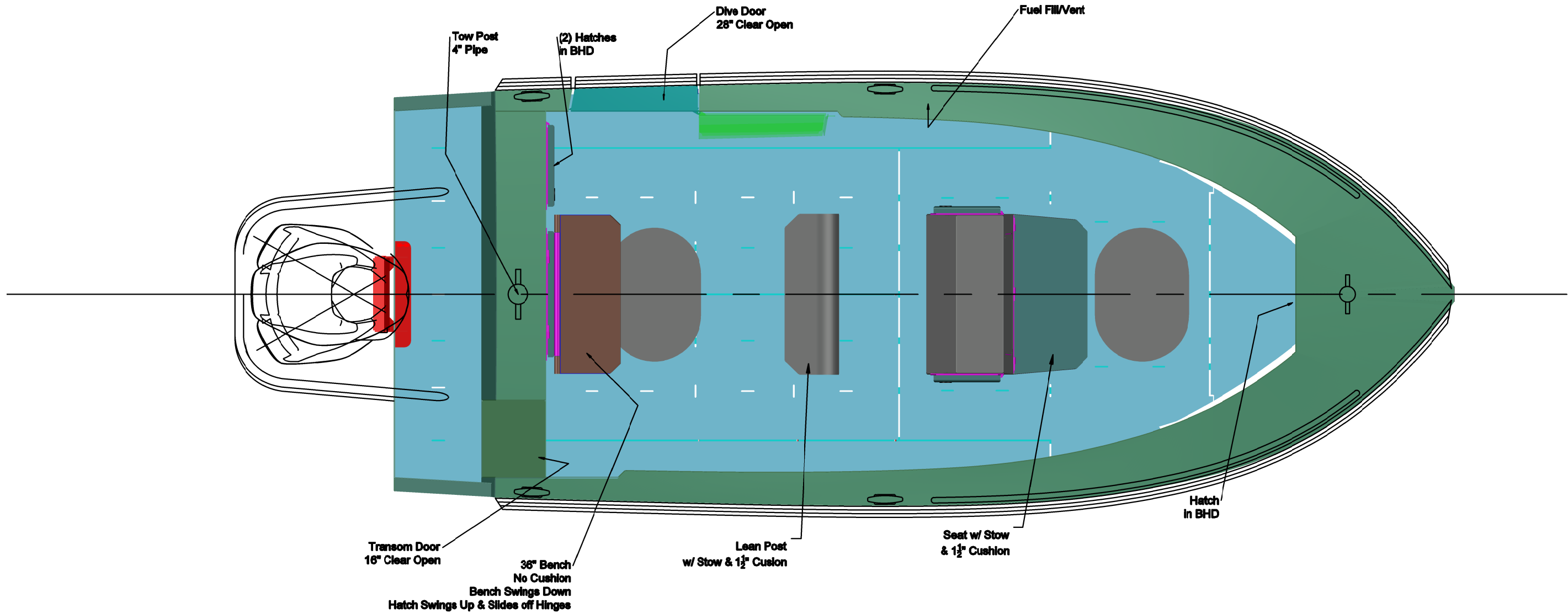

Transom Door
16" Clear Open

36" Bench
No Cushion
Bench Swings Down
Hatch Swings Up & Slides off Hinges

Lean Post
w/ Stow & 1 1/2" Cushion

Seat w/ Stow
& 1 1/2" Cushion

Hatch
in BHD

DECK PLAN- Shaded		
20' x 8'5" Rescue Skiff		
SCALE 1/2"=1'	DES/DWN WAL	DATE 7/16/24
Response Marine, Inc. Newburyport, MA, www.responsemarine.com		REV DWG NO. 630-1-1

This drawing and referenced information represent the intellectual property of Response Marine, Inc. Use, reproduction, or transmittal of drawings and referenced NC part files requires pre-payment of licensing fee to Response Marine, Inc. Construction of each boat and component fabrication are licensed on a per boat basis, and require proof of payment for each unit built, prior to construction. Possession of this drawing and referenced information does not constitute the right to use. Proper boat construction and outfitting requires knowledge and expertise beyond the scope of this, and other, drawings, and this knowledge and expertise is the sole responsibility of the builder.

REV.	DESCRIPTION

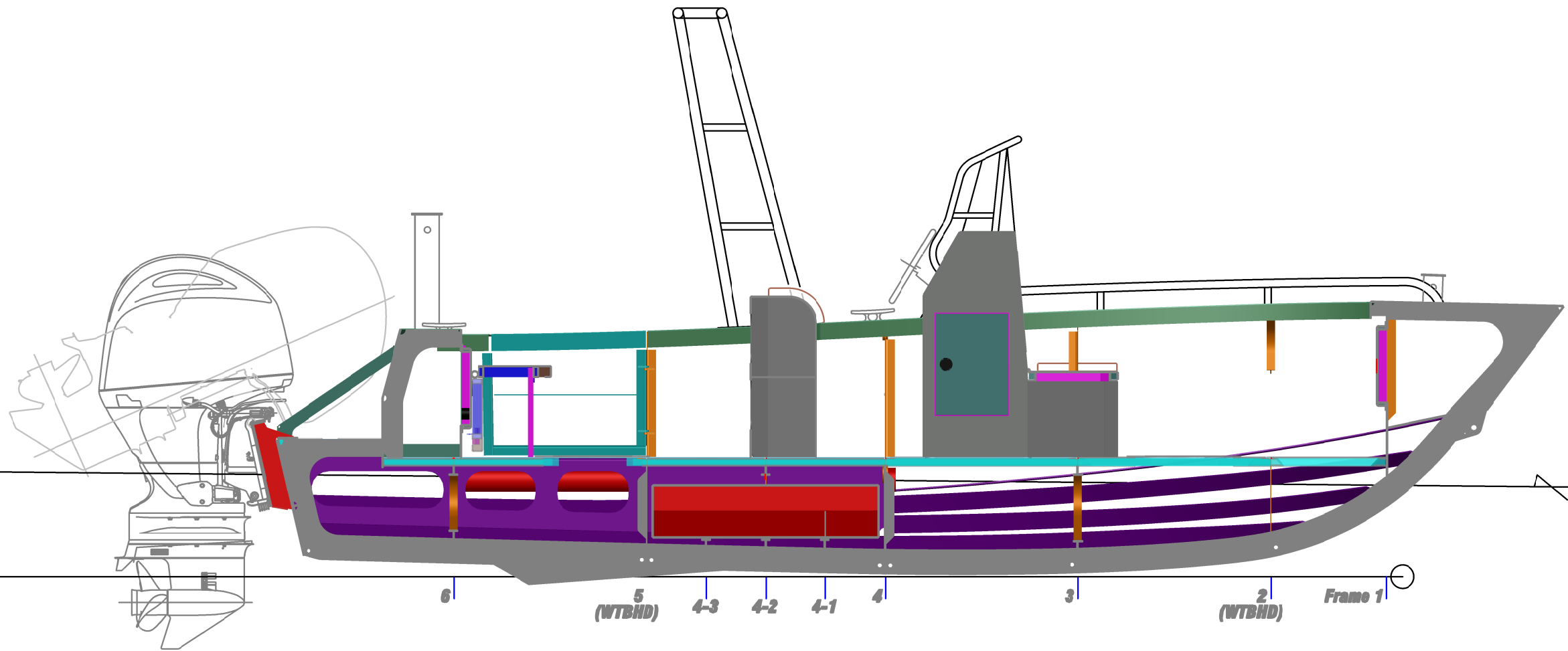

Est Hvy WL
5,201# @ 10.37
1.42',55"

This drawing and referenced information represent the intellectual property of Response Marine, Inc. Use, reproduction, or transmittal of drawings and referenced NC part files requires pre-payment of licensing fee to Response Marine, Inc. Construction of each boat and component fabrication are licensed on a per boat basis, and require proof of payment for each unit built, prior to construction. Possession of this drawing and referenced information does not constitute the right to use. Proper boat construction and outfitting requires knowledge and expertise beyond the scope of this, and other, drawings, and this knowledge and expertise is the sole responsibility of the builder.

REV. DESCRIPTION

INBOARD PRO- Shaded		
20' x 8'5" Rescue Skiff		
SCALE 3/8"=1'	DES/DWN WAL	DATE 7/16/24
Response Marine, Inc. Newburyport, MA, www.responsemarine.com		REV DWG NO. 630-1-2

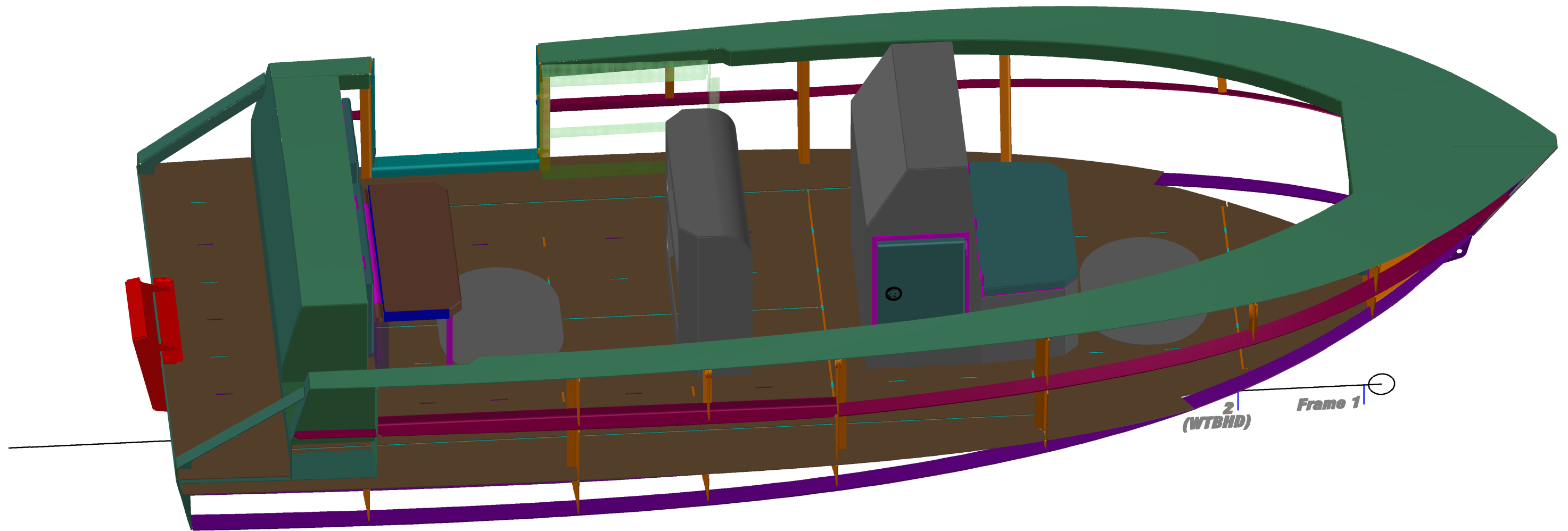

Not Shown:

- Full Width Arch
- Misc. Handrails
- Tow Post
- Rub Rails
- TS & Bot Skins

This drawing and referenced information represent the intellectual property of Response Marine, Inc. Use, reproduction, or transmittal of drawings and referenced NC part files requires pre-payment of licensing fee to Response Marine, Inc. Construction of each boat and component fabrication are licensed on a per boat basis, and require proof of payment for each unit built, prior to construction. Possession of this drawing and referenced information does not constitute the right to use. Proper boat construction and outfitting requires knowledge and expertise beyond the scope of this, and other, drawings, and this knowledge and expertise is the sole responsibility of the builder.

PORT PERSPECTIVE		
20' x 8'5" Rescue Skiff		
SCALE NONE	DES/DWN WAL	DATE 7/16/24
Response Marine, Inc.		REV
Newburyport, MA, www.responsemarine.com		DWG NO. 630-1-4

REV.	DESCRIPTION

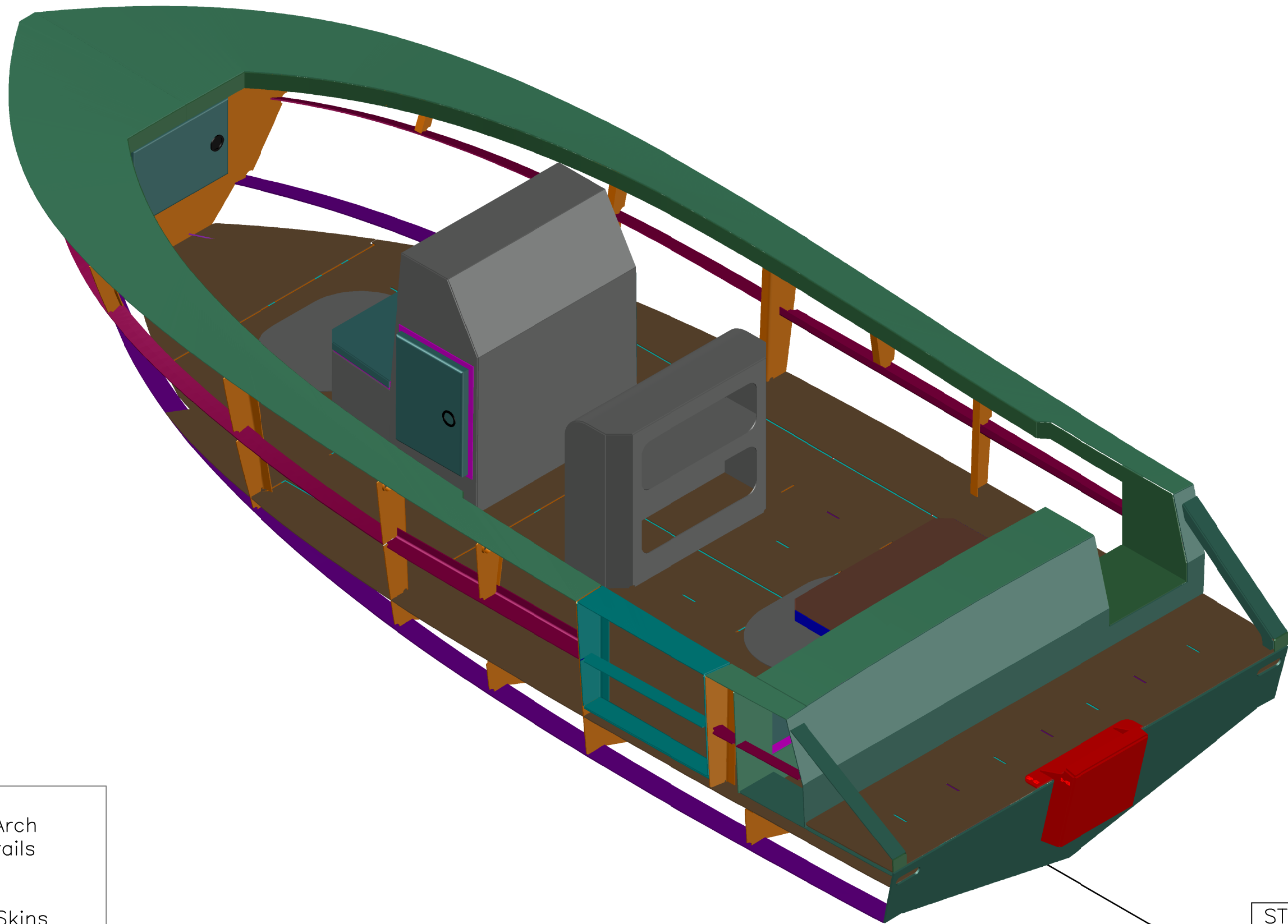

Not Shown:

- Full Width Arch
- Misc. Handrails
- Tow Post
- Rub Rails
- TS & Bot Skins

This drawing and referenced information represent the intellectual property of Response Marine, Inc. Use, reproduction, or transmittal of drawings and referenced NC part files requires pre-payment of licensing fee to Response Marine, Inc. Construction of each boat and component fabrication are licensed on a per boat basis, and require proof of payment for each unit built, prior to construction. Possession of this drawing and referenced information does not constitute the right to use. Proper boat construction and outfitting requires knowledge and expertise beyond the scope of this, and other, drawings, and this knowledge and expertise is the sole responsibility of the builder.

STERN QTR. PERSPECTIVE		
20' x 8'5" Rescue Skiff		
SCALE	DES/DWN	DATE
NONE	WAL	7/16/24
Response Marine, Inc.		REV
Newburyport, MA, www.responsemarine.com		DWG NO. 630-1-5

REV.	DESCRIPTION

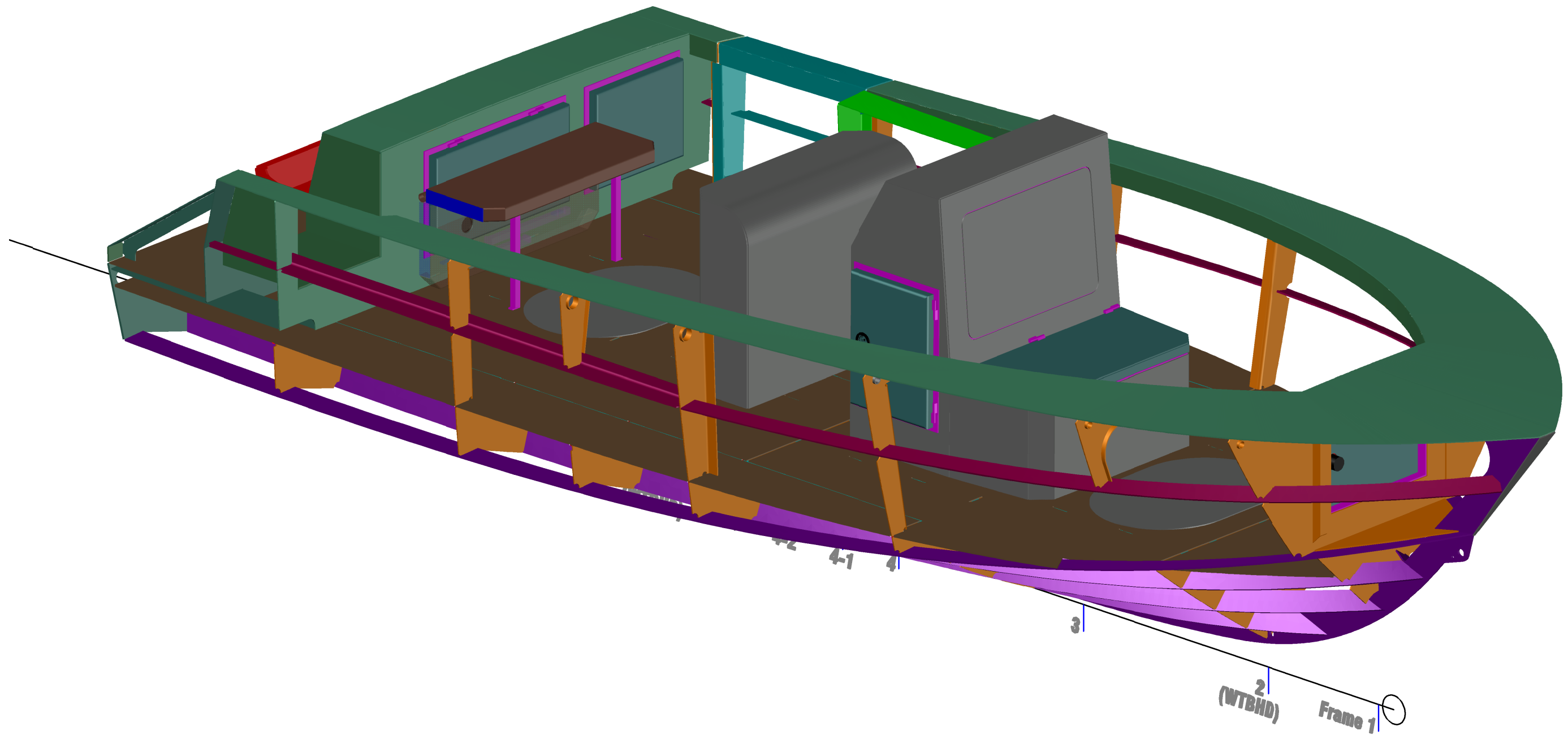

Not Shown:

- Full Width Arch
- Misc. Handrails
- Tow Post
- Rub Rails
- TS & Bot Skins

This drawing and referenced information represent the intellectual property of Response Marine, Inc. Use, reproduction, or transmittal of drawings and referenced NC part files requires pre-payment of licensing fee to Response Marine, Inc. Construction of each boat and component fabrication are licensed on a per boat basis, and require proof of payment for each unit built, prior to construction. Possession of this drawing and referenced information does not constitute the right to use. Proper boat construction and outfitting requires knowledge and expertise beyond the scope of this, and other, drawings, and this knowledge and expertise is the sole responsibility of the builder.

BOW QTR. PERSPECTIVE		
20' x 8'5" Rescue Skiff		
SCALE NONE	DES/DWN WAL	DATE 7/16/24
Response Marine, Inc. Newburyport, MA, www.responsemarine.com		REV DWG NO. 630-1-6

REV.	DESCRIPTION

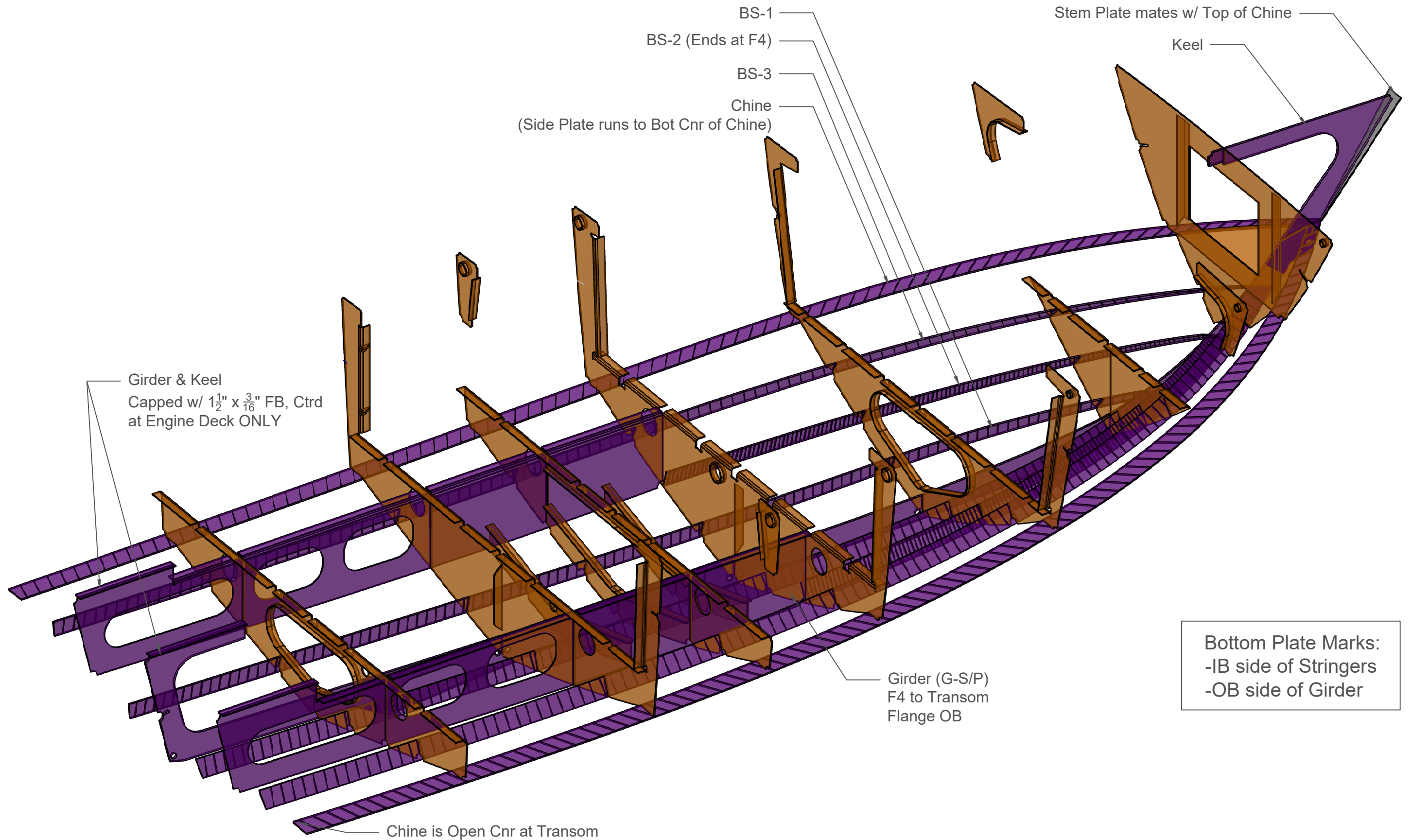

This drawing and referenced information represent the intellectual property of Response Marine, Inc. Use, reproduction, or transmittal of drawings and referenced NC part files requires pre-payment of licensing fee to Response Marine, Inc. Construction of each boat and component fabrication are licensed on a per boat basis, and require proof of payment for each unit built, prior to construction. Possession of this drawing and referenced information does not constitute the right to use. Proper boat construction and outfitting requires knowledge and expertise beyond the scope of this, and other, drawings, and this knowledge and expertise is the sole responsibility of the builder.

REV.	DESCRIPTION

BOTTOM STRUCTURE		
20' x 8'5" Rescue Skiff		
SCALE NONE	DES/DWN WAL	DATE 7/16/24
Response Marine, Inc. Newburyport, MA, www.responsemarine.com		REV DWG NO. 630-2-4

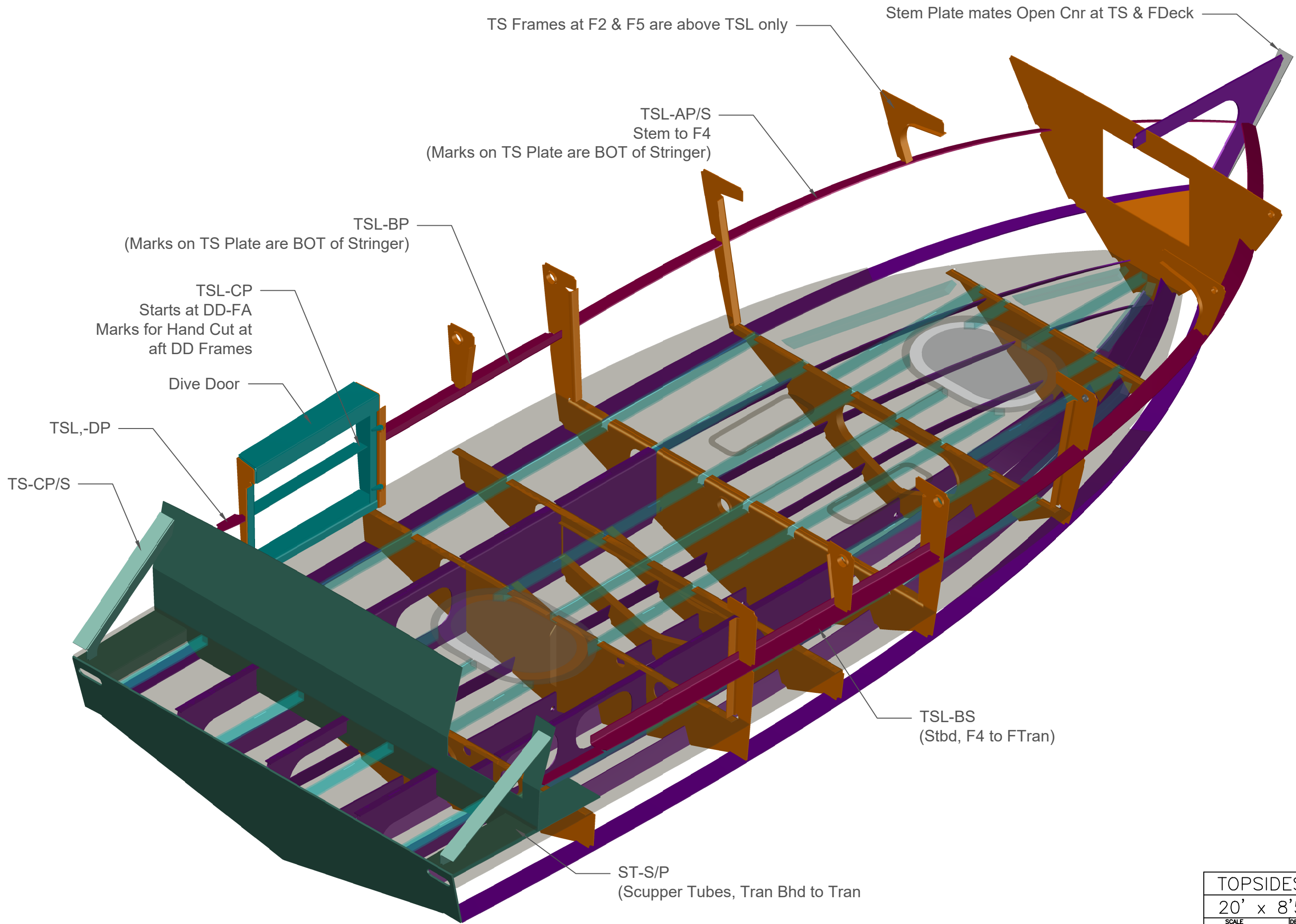

This drawing and referenced information represent the intellectual property of Response Marine, Inc. Use, reproduction, or transmittal of drawings and referenced NC part files requires pre-payment of licensing fee to Response Marine, Inc. Construction of each boat and component fabrication are licensed on a per boat basis, and require proof of payment for each unit built, prior to construction. Possession of this drawing and referenced information does not constitute the right to use. Proper boat construction and outfitting requires knowledge and expertise beyond the scope of this, and other, drawings, and this knowledge and expertise is the sole responsibility of the builder.

REV.	DESCRIPTION

TOPSIDES STRUCTURE		
20' x 8'5" Rescue Skiff		
SCALE NONE	DES/DWN WAL	DATE 7/16/24
Response Marine, Inc. Newburyport, MA, www.responsemarine.com		REV DWG NO. 630-2-5

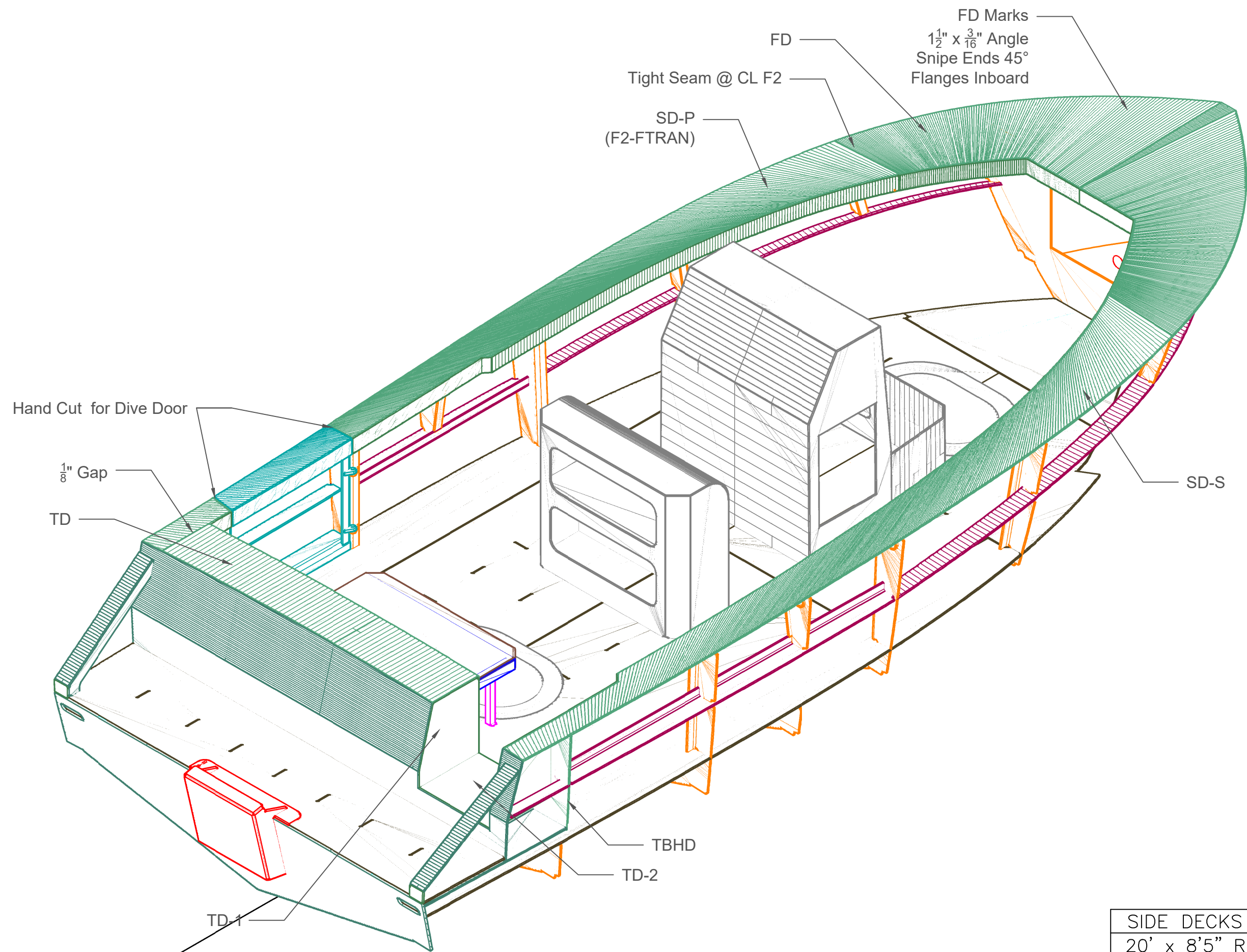

This drawing and referenced information represent the intellectual property of Response Marine, Inc. Use, reproduction, or transmittal of drawings and referenced NC part files requires pre-payment of licensing fee to Response Marine, Inc. Construction of each boat and component fabrication are licensed on a per boat basis, and require proof of payment for each unit built, prior to construction. Possession of this drawing and referenced information does not constitute the right to use. Proper boat construction and outfitting requires knowledge and expertise beyond the scope of this, and other, drawings, and this knowledge and expertise is the sole responsibility of the builder.

REV.	DESCRIPTION

SIDE DECKS		
20' x 8'5" Rescue Skiff		
SCALE NONE	DES/DWN WAL	DATE 7/16/24
Response Marine, Inc. Newburyport, MA, www.responsemarine.com		REV DWG NO. 630-2-8

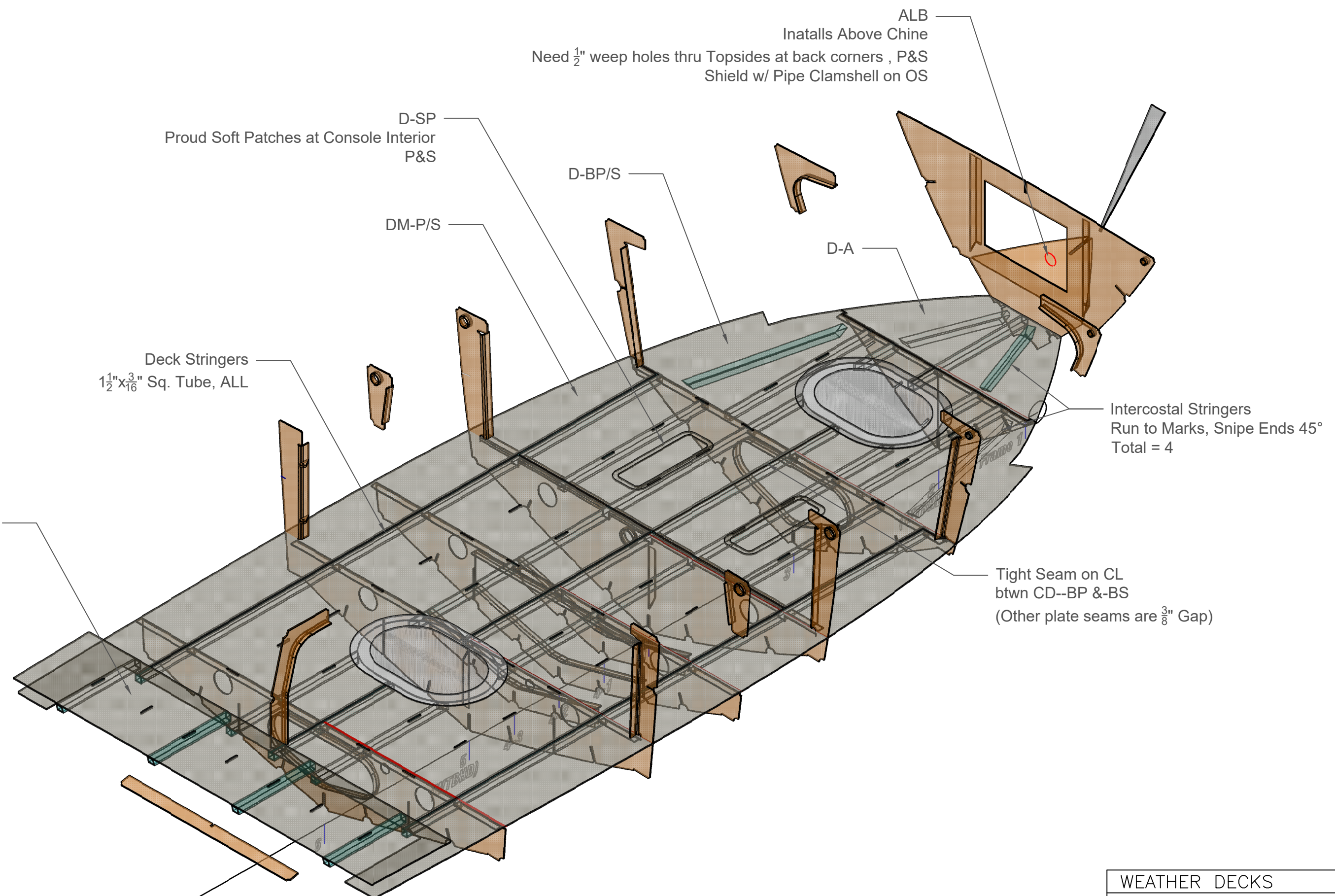

Need 1/2" weep holes thru Topsides at back corners , P&S Shield w/ Pipe Clamshell on OS

D-SP
Proud Soft Patches at Console Interior P&S

D-BP/S

DM-P/S

ALB

Installs Above Chine

D-A

Deck Stringers
1 1/2" x 3/16" Sq. Tube, ALL

Intercostal Stringers
Run to Marks, Snipe Ends 45°
Total = 4

DB-D
(Engine Deck)

Tight Seam on CL
btwn CD--BP &-BS
(Other plate seams are 3/8" Gap)

This drawing and referenced information represent the intellectual property of Response Marine, Inc. Use, reproduction, or transmittal of drawings and referenced NC part files requires pre-payment of licensing fee to Response Marine, Inc. Construction of each boat and component fabrication are licensed on a per boat basis, and require proof of payment for each unit built, prior to construction. Possession of this drawing and referenced information does not constitute the right to use. Proper boat construction and outfitting requires knowledge and expertise beyond the scope of this, and other, drawings, and this knowledge and expertise is the sole responsibility of the builder.

REV. DESCRIPTION

WEATHER DECKS		
20' x 8'5" Rescue Skiff		
SCALE NONE	DES/DWN WAL	DATE 7/16/24
Response Marine, Inc.		REV
Newburyport, MA, www.responsemarine.com		DWG NO. 630-2-10

Soft Patch at Seat Back
(CON-B-SP & -SPR)

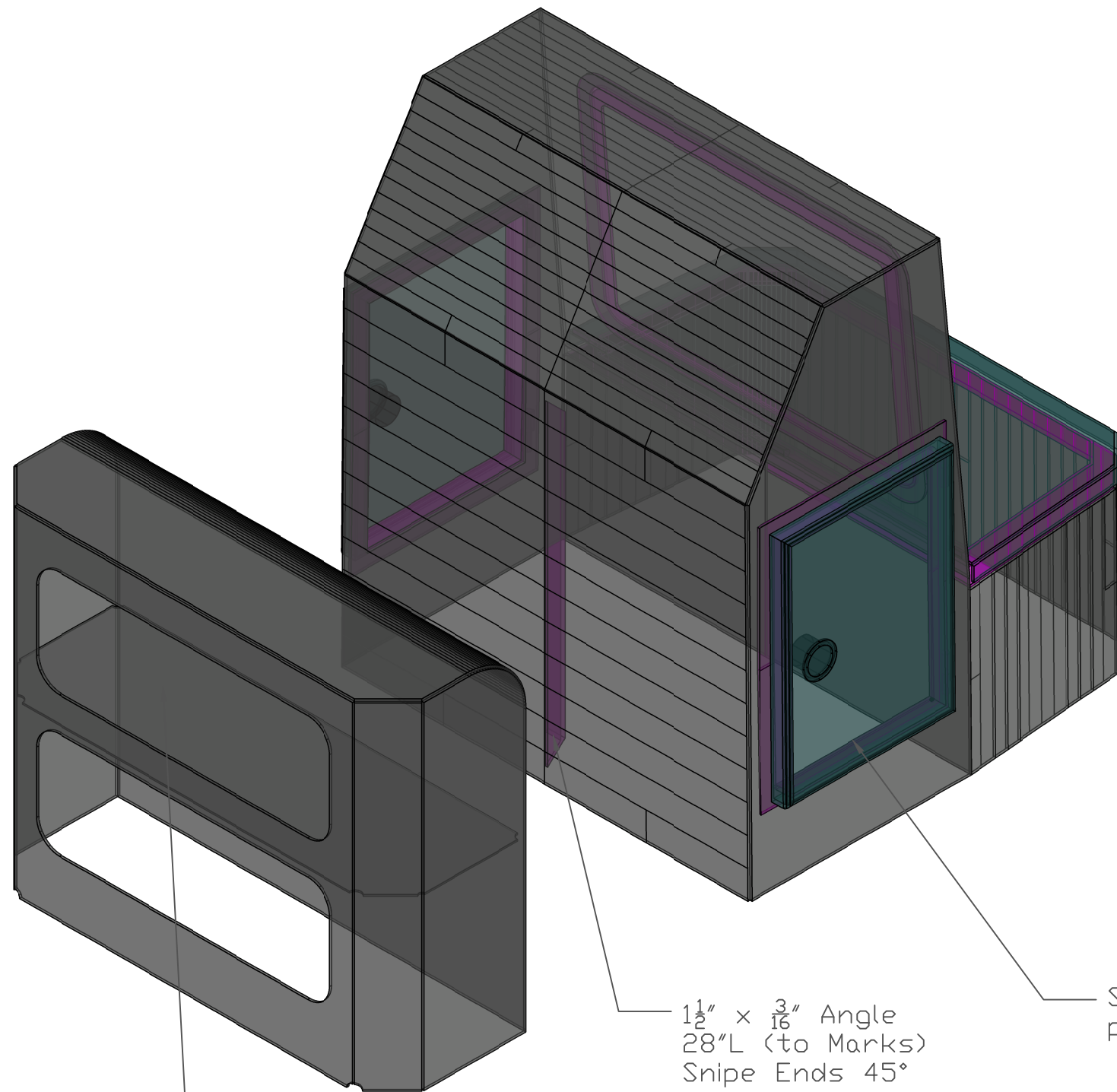

Lean Post w/ Open Bins & Shelf

1 1/2" x 3/16" Angle
28"L (to Marks)
Snipe Ends 45°

Side Hatches
per Dwg #630-7-1

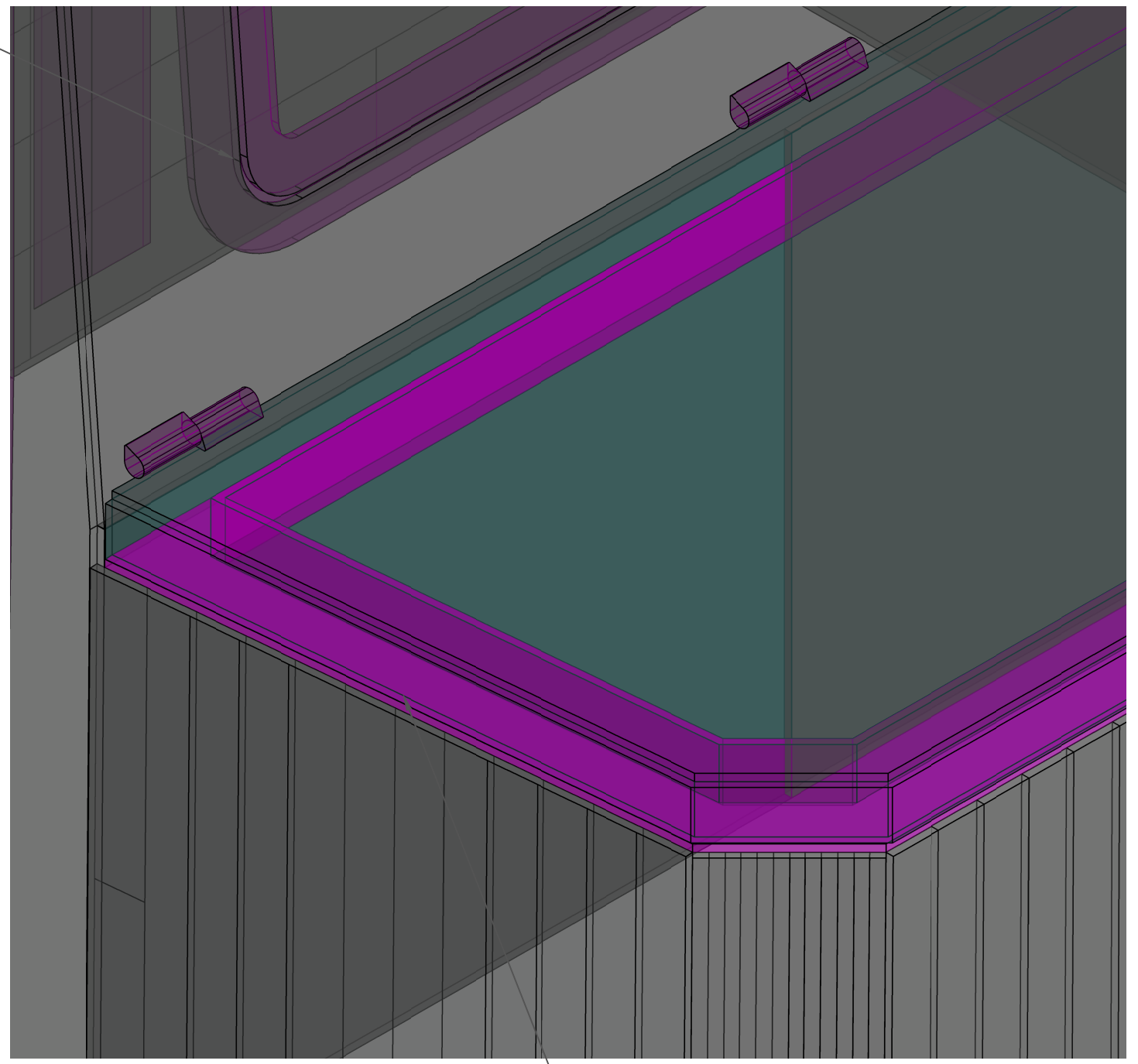

1 1/2" x 3/16" Angle Frame
1/8" Gap at Lid for Gasket
Gasket attached to Lid

This drawing and referenced information represent the intellectual property of Response Marine, Inc. Use, reproduction, or transmittal of drawings and referenced NC part files requires pre-payment of licensing fee to Response Marine, Inc. Construction of each boat and component fabrication are licensed on a per boat basis, and require proof of payment for each unit built, prior to construction. Possession of this drawing and referenced information does not constitute the right to use. Proper boat construction and outfitting requires knowledge and expertise beyond the scope of this, and other, drawings, and this knowledge and expertise is the sole responsibility of the builder.

REV. DESCRIPTION

Console and Lean Post		
20' x 8'5" Rescue Skiff		
SCALE NONE	DES/DWN WAL	DATE 7/16/24
Response Marine, Inc. Newburyport, MA, www.responsemarine.com		REV DWG NO. 630-4-1

For 1" Conduit, Stbd ONLY
 or 1" Pipe Collar x 1" L
 Confirm Collar acceptable for Customer

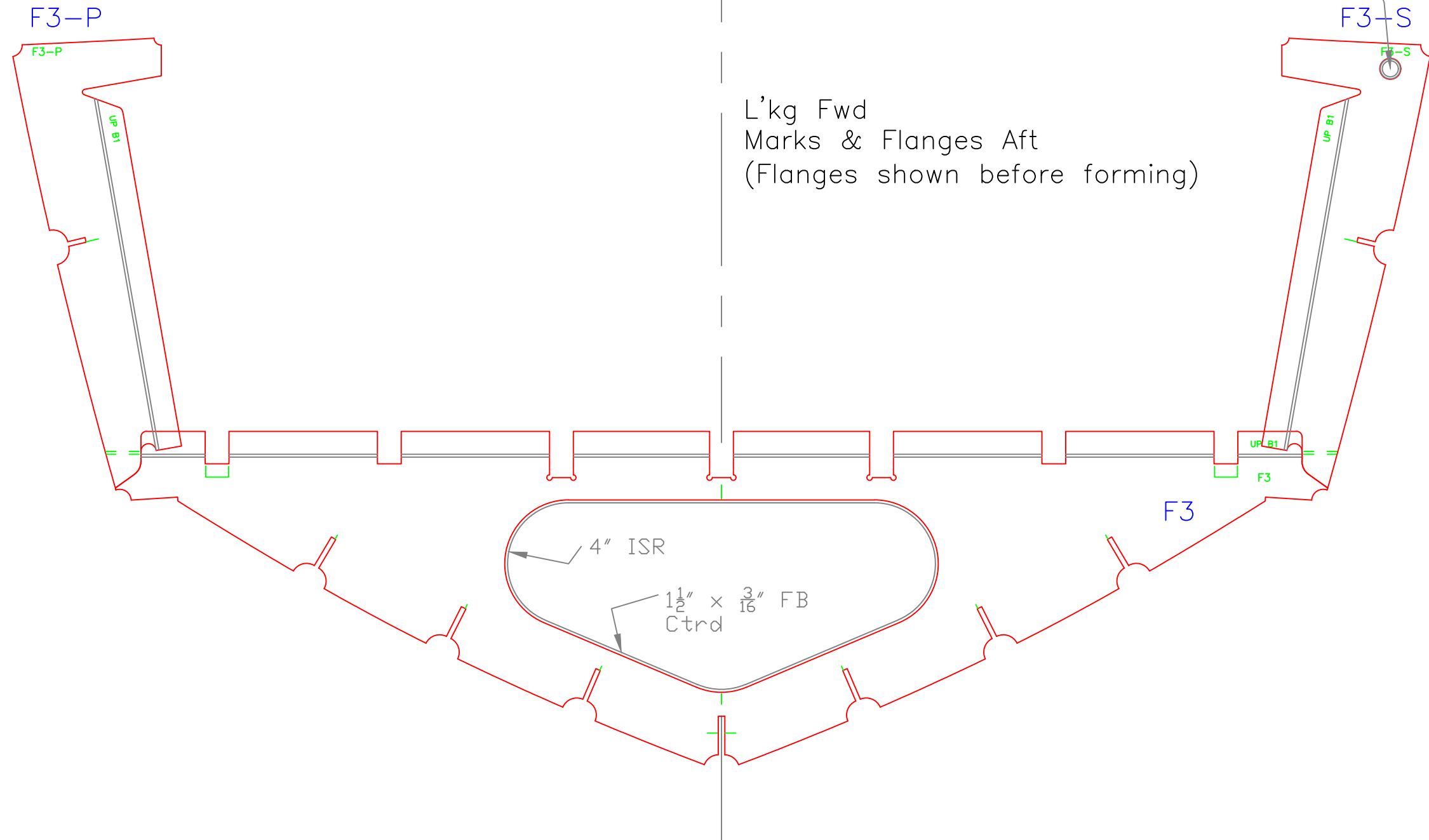

This drawing represents significant intellectual property of Response Marine, Inc. Reproduction of this drawing in any form, in whole or in part, including transmissions of any type, to third parties is forbidden without the prior written consent of Response Marine, Inc.

REV.	DESCRIPTION

Frame 3		
20' x 8'5" Rescue Skiff		
SCALE 1 1/2" = 1'	DES/DWN WAL	DATE 7/16/24
Response Marine, Inc.		SHEET
Newburyport, MA, www.responsemarine.com		DWG NO. 630-F-3

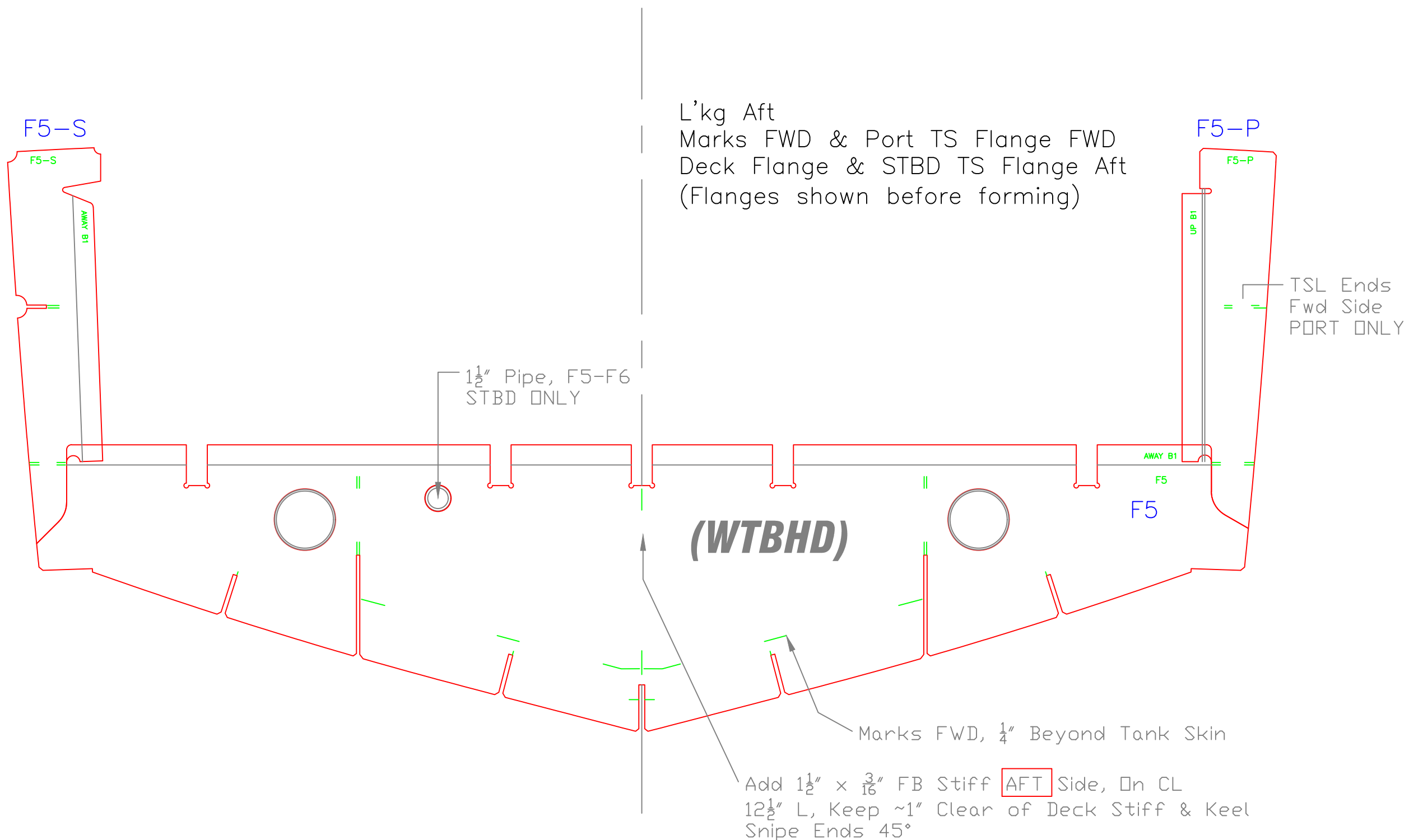

This drawing represents significant intellectual property of Response Marine, Inc. Reproduction of this drawing in any form, in whole or in part, including transmissions of any type, to third parties is forbidden without the prior written consent of Response Marine, Inc.

REV.	DESCRIPTION

Frame 5, WT BHD		
20' x 8'5" Rescue Skiff		
SCALE 1 1/2" = 1'	DES/DWN WAL	DATE 7/16/24
Response Marine, Inc.		SHEET
Newburyport, MA, www.responsemarine.com		DWG NO. 630-F-5