

PRELIMINARY

REV.	DESCRIPTION

ARRANGEMENT PLAN		
40' Jet Cruiser- Setz		
SCALE 3/8"=1'	DES/DWN WAL	DATE 1/9/19
Response Marine, Inc.		REV.
Newburyport, MA, www.responsemarine.com		DWG. NO. 585-P2

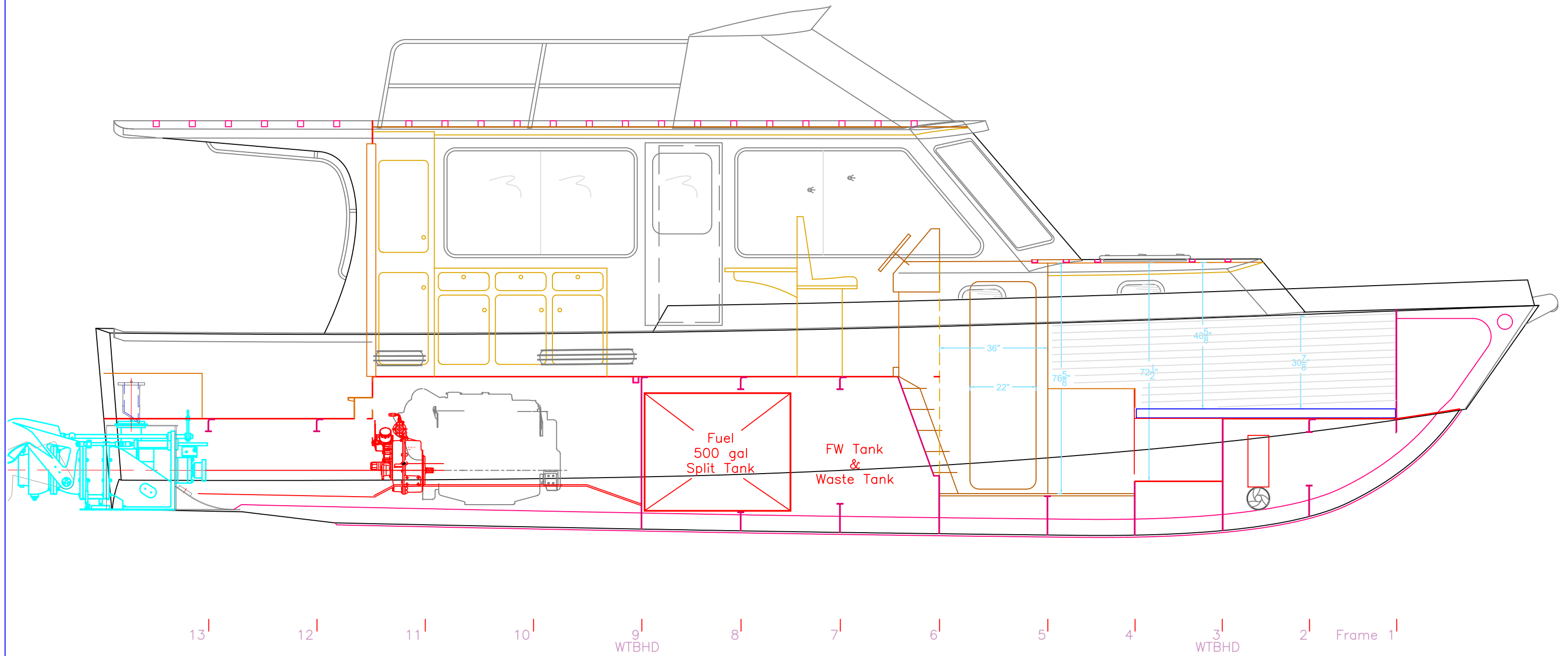

PRELIMINARY

INBOARD PROFILE		
40' Jet Cruiser-Setz		
SCALE 3/8"=1'	DES/DWN WAL	DATE 1/9/19
Response Marine, Inc. Newburyport, MA, www.responsemarine.com		REV DWG. NO. 585-P3

REV.	DESCRIPTION

Response Marine, Inc.

Design	Dwg	Description	Date	REV
<u>Setz- 40' Jet</u>				
	585 -1	Lines Plan	2/1/19	Rev from 1/23/19
	-2-1	Keel Layout	2/1/19	
	-2-2	Engine Girder Layout	2/1/19	
	-2-3	Engine Girder Flanges & Frames	2/1/19	
	-2-4	Bottom Plate Layout	2/1/19	
	-2-5	Bottom Stringers	2/1/19	
	-2-6	Chine Plate Layout	2/1/19	
	-2-7	Topside Plate Layout	2/1/19	
	-2-8	Bow Cone	2/1/19	
	-2-9	Transom	2/1/19	
	-2-10	Foredeck	2/1/19	
	-2-11	Side Decks & Coamings	2/1/19	
	-2-12	Pilothouse Deck	2/1/19	
	-2-13	Cockpit Deck	2/1/19	
	-2-14	Fwd Cabin V Berth	2/1/19	
	-2-15	Thruster Dblr & Fairing	2/1/19	
	-2-16	Stair Tray at F6	2/1/19	
	-2-17	Sheer Widths	2/1/19	
	3-1	Fuel Tank- Split 500 gal	2/1/19	
	-CR-1	Hull Joint Details	2/1/19	
	-B-1	Forming: Flange- B-1	1/28/19	
	-B-2	Forming: Flange- B-2	1/28/19	
	-FR	Frame Dimensions	1/29/19	
	-F0	Frame 0, Cant Frame	2/1/19	
	-F1	Frame 1	1/29/19	
	-F2	Frame 2	1/29/19	
	-F3	Frame 3, WTBHD	1/29/19	
	-F4	Frame 4	1/29/19	
	-4a	Head Bulkhead	1/29/19	
	-F5	Frame 5	1/29/19	
	-F6	Frame 6	1/29/19	
	-F7	Frame 7	1/29/19	
	-F8	Frame 8	1/29/19	
	-F-9	Frame 9, WTBHD	1/29/19	
	-F-10	Frame 10	1/29/19	
	-F-11	Frame 11	1/29/19	
	-F-12	Frame 12	1/29/19	
	-F-13	Frame 13	1/29/19	

Response Marine, Inc.
 NC Cut Parts
 #585, Setz 40'
 File: RMIDes\585...

Revised: 2/4/19
 Print Date: 2/4/19

3/16" Parts-5052

<u>Part #</u>	<u>Pieces</u>	<u>Description</u>	<u>Form</u>	<u>Form Detail</u>	<u>Nested Plate #</u>	<u>Cut Batch</u>
BTF-J	1	Bow ThrusterFairing, Jig			3A- 1	2
BTF-P	1	Bow Thruster Fairing, Port	Y	Bump to Jig	3A- 1	2
BTF-S	1	Bow Thruster Fairing, Stbd	Y	Bump to Jig	3A- 1	2
EVD-A	2	Engine Vent Dam, Fwd, F9-F10	Y	1/4" R as marked	3A- 1,2	2
EVD-B	2	Engine Vent Dam, Aft, F11-PH Bhd	Y	1/4" R as marked	3A- 1	2
FC-BP	1	Fwd Cabin, Berth Flat, Port			3A- 2	2
FC-BS	1	Fwd Cabin, Berth Flat, Stbd			3A- 1	2
FC-BV	1	Fwd Cabin, V Berth Footwell	Y	1/4" R as marked	3A- 2	2
FC-F6	1	Fwd Cabin, F6 Insert at CL Stairs	Y	1/4" R as marked	3A- 1	2
J-FD	1	Jig, Foredeck, Transverse 3" fwd of F2	Y	1/4" R as marked	3A- 2	2
J-T1	1	Transom Jig- Lower			3A- 1	2
J-T2	1	Transom Jig-Upper			3A- 1	2
	14	Total 3/16" 5052 Parts				

3/16" Parts-5086 Marine

<u>Part #</u>	<u>Pieces</u>	<u>Description</u>	<u>Form</u>	<u>Form Detail</u>	<u>Nested Plate #</u>	<u>Cut Batch</u>
F5-P	1	Frame 5, Port Bhd	Y	Up Flange B-2	3- 1	1
F5-S	1	Frame 5, Stbd			3- 1	1
H-BHD	1	Head Bulkhead	Y	Up Flange B-2	3- 1	1
TSL-3B-P	1	Topside Longitudinal 3, PH Bhd to Transom, Port	Y	Up Flange B-2	3- 1	1
TSL-3B-S	1	Topside Longitudinal 3, PH Bhd to Transom, Stbd	Y	Up Flange B-2	3- 1	1
ALB	1	Anchor Locker Bottom			3- 2	2
BC	1	Bow Cone	Y	Bump	3- 5	2
FD-P	1	Fordeck, Port			3- 3	2
FD-S	1	Foredeck, Stbd			3- 2,	2
FT-1	1	Fuel Tank, Skin	Y	1/2" R as marked	3- 4	2
FT-2	2	Fuel Tank, Ends			3- 5	2
FT-3	1	Fuel Tank, Transverse DIVIDER			3- 5	2
FT-4	4	Fuel Tank, Long'l Baffles			3- 2,3,6,7	2
FT-5	1	Fuel Tank, Top Forward			3- 8	2
FT-6	1	Fuel Tank, Top Aft			3- 8	2
J-BC-1	1	Jig, Bow Cone, Upper			3- 5	2
J-BC-2	1	Jig, Bow Cone, Lower			3- 5	2
MD-C-P	1	Deck Margin Plate, Cockpit, F11- Transom, Port			3- 5	2
MD-C-S	1	Deck Margin Plate, Cockpit, F11-Transom, Stbd			3- 4	2
MD-PH-P	1	Deck Margin Plate, Pilothouse, Port			3- 4	2
MD-PH-S	1	Deck Margin Plate, Pilothouse, Stbd			3- 5	2
MD-T	1	Deck Margin Plate, Cockpit, F13-Transom			3- 4	2
SD-AP	1	Side Deck Fwd, Port			3- 6	2
SD-AS	1	Side Deck Fwd, Stbd			3- 7	2
SD-BP	1	Side Deck Aft, Port			3- 5	2
SD-BS	1	Side Deck Aft, Stbd			3- 4	2
SDC-P	1	Side Deck Coaming, Port			3- 5	2
SDC-S	1	Side Deck Coaming, Stbd			3- 4	2
TD	1	Transom Deck			3- 2	2
TDC	1	Transom Deck Coaming			3- 2	2
TS-AP	1	Topsides, Fwd Port			3- 6	2
TS-AS	1	Topsides, Fwd Stbd			3- 7	2
TS-BP	1	Topsides, Aft Port			3- 2	2
TS-BS	1	Topsides, Aft Stbd			3- 3	2
	38	Total 3/16" 5086 Parts				

1/4" Parts- 5086 Marine

<u>Part #</u>	<u>Pieces</u>	<u>Description</u>		<u>Nested Plate #</u>	<u>Cut Batch</u>
F1	1	Frame 1, BHD		4- 2	1
F10	1	Frame 10, Body	Y Up, Flange B-1	4- 4	1
F10-P	1	Frame 10, Upper Port		4- 2	1
F10-S	1	Frame 10, Upper Stbd		4- 2	1
F11	1	Frame 11, Body	Y Away, Flange B-1	4- 2	1
F11-P	1	Frame 11, Upper Port		4- 2	1
F11-S	1	Frame 11, Upper Stbd		4- 2	1
F12	1	Frame 12, Body	Y Up, Flange B-1	4- 2	1
F12-P	1	Frame 12, Upper Port		4- 2	1
F12-S	1	Frame 12, Upper Stbd		4- 2	1
F13	1	Frame 13, Body	Y Up, Flange B-1	4- 2	1
F13-P	1	Frame 13, Upper Port		4- 2	1
F13-S	1	Frame 13, Upper Stbd		4- 2	1
F2	1	Frame 2, Body	Y Up, Flange B-1	4- 3	1
F2-P	1	Frame 2, Upper Port	Y Up, Flange B-1	4- 1	1
F2-S	1	Frame 2, Upper Stbd	Y Up, Flange B-1	4- 1	1
F3	1	Frame 3, Body	Y Away, Flange B-1	4- 2	1
F3-P	1	Frame 3, Upper Port	Y Away, Flange B-1	4- 1	1
F3-S	1	Frame 3, Upper Stbd	Y Away, Flange B-1	4- 1	1
F4	1	Frame 4, Body	Y Up, Flange B-1	4- 2	1
F4-P	1	Frame 4, Upper Port	Y Up, Flange B-1	4- 1	1
F4-S	1	Frame 4, Upper Stbd	Y Up, Flange B-1	4- 1	1
F6-P	1	Frame 6, Bhd, Port		4- 1	1
F6-S	1	Frame 6, Bhd, Stbd		4- 1	1
F7	1	Frame 7, Body	Y Up, Flange B-1	4- 3	1
F7-P	1	Frame 7, Upper Port		4- 2	1
F7-S	1	Frame 7, Upper Stbd		4- 2	1
F8	1	Frame 8, Body	Y Up, Flange B-1	4- 3	1
F8-P	1	Frame 8, Upper Port		4- 1	1
F8-S	1	Frame 8, Upper Stbd		4- 1	1
F9	1	Frame 9, WT BHD, Body	Y Away, Flange B-1	4- 4	1
F9-D	2	Frame 9 Doublers at Engine Girder, Aft Side		4- 2	1
F9-P	1	Frame 9, Upper Port		4- 2	1
F9-S	1	Frame 9, Upper Stbd		4- 2	1
B-AP	1	Bottom Plate, Fwd Port		4- 4	2
B-AS	1	Bottom Plate, Fwd Stbd		4- 3	2
B-BP	1	Bottom Plate Aft Port		4- 6	2
B-BS	1	Bottom Plate Aft Stbd		4- 5	2
BL-1P	1	Bottom Longitudinal 1 (Keel at F2 to F12), Port		4- 3	2
BL-1S	1	Bottom Longitudinal 1 (Keel at F2 to F12), Stbd		4- 4	2
BL-2P	1	Bottom Longitudinal 2 (Fwd of F2 to F9), Port		4- 5	2
BL-2S	1	Bottom Longitudinal 2 (Fwd of F2 to F12), Stbd		4- 6	2
BL-3AP	1	Bottom Longitudinal 3 (Fwd of F2 to F8), Port		4- 5	2
BL-3AS	1	Bottom Longitudinal 3 (Fwd of F2 to F8), Stbd		4- 6	2
BL-3BP	1	Bottom Longitudinal 3 (F8 to Transom), Port		4- 5	2
BL-3BS	1	Bottom Longitudinal 3 (F8 to Transom), Stbd		4- 6	2
BL-4AP	1	Bottom Longitudinal 4 (Fwd of F1 to F11), Port		4- 3	2
BL-4AS	1	Bottom Longitudinal 4 (Fwd of F1 to F11), Stbd		4- 4	2
BL-4BP	1	Bottom Longitudinal 4 (F11 to Transom), Port		4- 5	2
BL-4BS	1	Bottom Longitudinal 4 (F11 to Transom), Stbd		4- 6	2
BL-5AP	1	Bottom Longitudinal 5 (Fwd of F1 to F9), Port		4- 5	2
BL-5AS	1	Bottom Longitudinal 5 (Fwd of F1 to F9), Stbd		4- 6	2
BL-5BP	1	Bottom Longitudinal 5 (F9 to Transom), Port		4- 5	2
BL-5BS	1	Bottom Longitudinal 5 (F9 to Transom), Stbd		4- 6	2
BT-D	2	Bow Thruster, Doubler		4- 3	2
F0-P	1	Frame 0, Cant Frame, Port		4- 5	2
F0-S	1	Frame 0, Cant Frame, Stbd		4- 5	2
F9a	2	Frame 9a, btwn engine girders		4- 5,6	2
F10a	2	Frame 10a, btwn engine girders		4- 5,6	2
F11a	2	Frame 11a, btwn engine girders		4- 5,6	2
F12a	1	Frame 12a, btwn engine girders		4- 5	2
JF-A	1	Jet Flat Fwd Transition Slant		4- 6	2
TR	1	Transom		4- 7	2
TSL-1-P	1	Topside Longitudinal 1, F6-Transom, Port		4- 6	2
TSL-1-S	1	Topside Longitudinal 1, F6-Transom, Stbd		4- 5	2
TSL-1T-P	1	Topside Longitudinal 1, Across Transom, Port		4- 5	2
TSL-1T-S	1	Topside Longitudinal 1, Across Transom, Stbd		4- 6	2
TSL-2A-P	1	Topside Longitudinal 2 (Stem-F7), Port		4- 5	2

TSL-2A-S	1	Topside Longitudinal 2 (Stem-F7), Stbd	4- 6	2
TSL-2B-P	1	Topside Longitudinal 2, F7-F11, Port	4- 5	2
TSL-2B-S	1	Topside Longitudinal 2, F7-F11, Stbd	4- 6	2
TSL-3A-P	1	Topside Longitudinal 3 (Stem-F6), Port	4- 5	2
TSL-3A-S	1	Topside Longitudinal 3 (Stem-F6), Stbd	4- 6	2
TSL-3T	1	Topside Longitudinal 3, Across Transom	4- 5	2

79 Total 1/4" Parts

3/8" Parts- 5086 Marine

<u>Part #</u>	<u>Pieces</u>	<u>Description</u>	<u>Nested Plate #</u>	
C-AP	1	Chine, fwd, Port	6- 1	2
C-AS	1	Chine, fwd, Stbd	6- 1	2
C-BP	1	Chine, mid fwd, Port	6- 1	2
C-BS	1	Chine, mid fwd, Stbd	6- 1	2
C-CP	1	Chine, mid aft, Port	6- 1	2
C-CS	1	Chine, mid aft, Stbd	6- 1	2
C-DP	1	Chine, aft, Port	6- 1	2
C-DS	1	Chine, aft, Stbd	6- 1	2
8		Total 3/8" Parts		

1/2" Parts- 5086 Marine

<u>Part #</u>	<u>Pieces</u>	<u>Description</u>	<u>Nested Plate #</u>	
EF-AP	1	Engine Bed Flange, Fwd, Port	8- 1	2
EF-AS	1	Engine Bed Flange, Fwd, Stbd	8- 1	2
EF-BP	1	Engine Bed Flange, Horizontal, Port	8- 2	2
EF-BS	1	Engine Bed Flange, Horizontal, Stbd	8- 2	2
EF-CP	1	Engine Bed Flange, Aft Transition, Port	8- 1	2
EF-CS	1	Engine Bed Flange, Aft Transition, Stbd	8- 1	2
EF-DP	1	Engine Bed Flange, Aft to F12, Port	8- 1	2
EF-DS	1	Engine Bed Flange, Aft to F12, Stbd	8- 1	2
EG-AP	1	Engine Girder, Fwd, Port	8- 1	2
EG-AS	1	Engine Girder, Fwd, Stbd	8- 1	2
EG-BP	1	Engine Girder Aft & Transom Vertical, Port	8- 1	2
EG-BS	1	Engine Girder Aft & Transom Vertical, Stbd	8- 1	2
K-A	1	Keel Tip, Foredeck Stiff	8- 1	2
K-B	1	Keel, Fwd	8- 2	2
K-C	1	Keel, Mid Fwd	8- 1	2
K-D	1	Keel, Mid Aft	8- 2	2
K-E	1	Keel, Aft	8- 1	2
17		Total 1/2" parts		
156		Total Cut Parts		

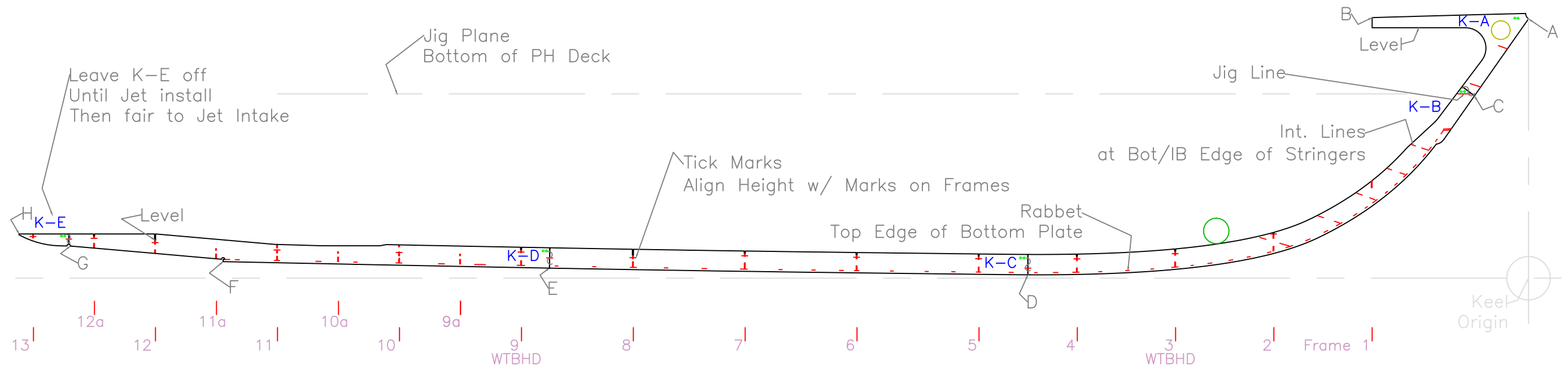

Response Marine, Inc.
 #585, Setz 40' Jet 1/29/19

Keel Points	Inches- sixteenths		Feet	
	Horizontal	Vertical	Horizontal	Vertical

A to Origin				
B to Origin				
C to Origin				
D to Origin				
E to Origin				
F to Origin				
G to Origin				
H to Origin				

Keel Points	ALIGNED (INCHES)						
	A	B	C	D	E	F	G

A to							
B to							
C to							
D to							
E to							
F to							
G to							
H to							

Keel Points	ALIGNED (mm)						
	A	B	C	D	E	F	G

A to							
B to							
C to							
D to							
E to							
F to							
G to							
H to							

This drawing represents significant intellectual property of Response Marine, Inc. Reproduction of this drawing in any form, in whole or in part, including transmissions of any type, to third parties is forbidden without the prior written consent of Response Marine, Inc.

REV.	DESCRIPTION

KEEL LAYOUT			
40' Jet Cruiser- Setz			
SCALE 3/8"=1'	DES/DWN WAL	DATE 2/1/19	REV
Response Marine, Inc. Newburyport, MA, www.responsemarine.com			DWG. NO. 585-2-1

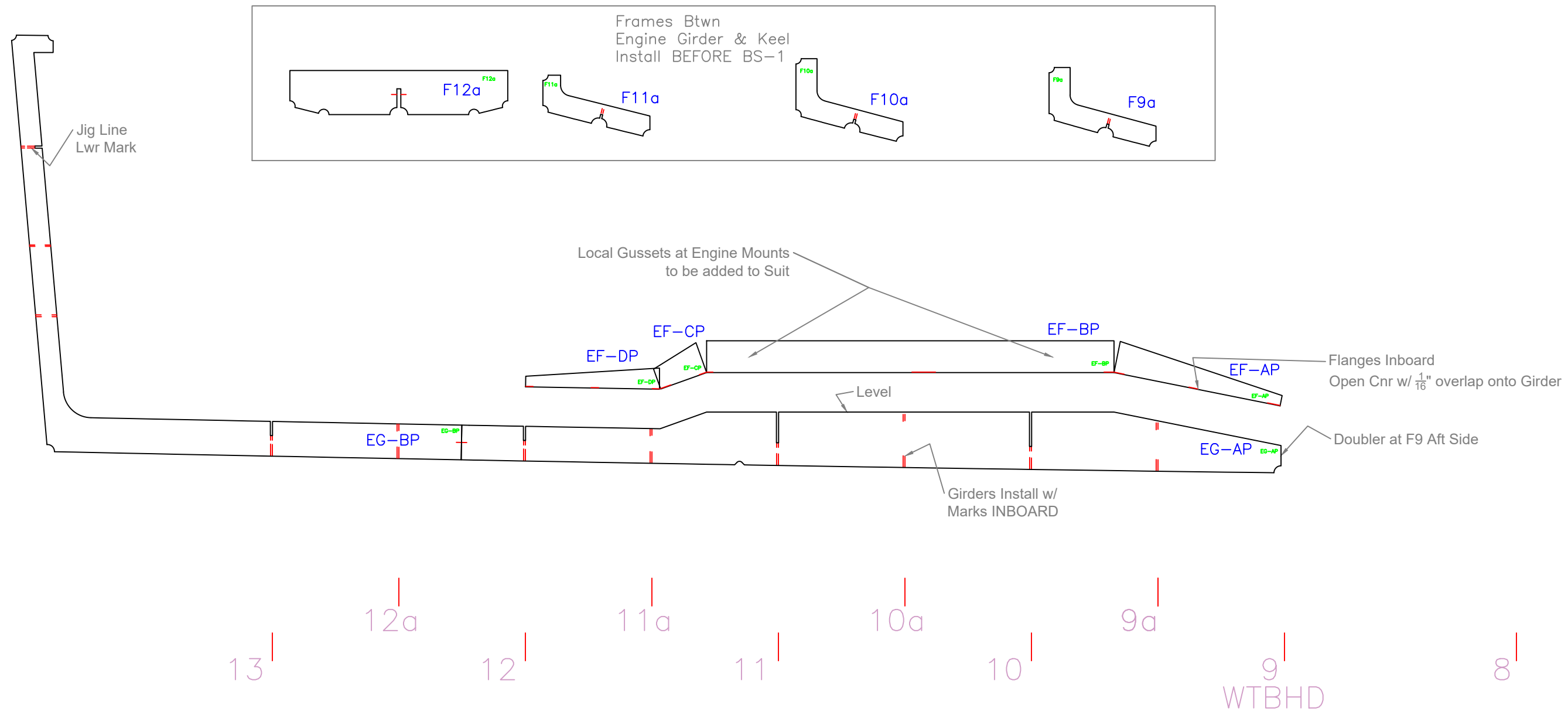

This drawing represents significant intellectual property of Response Marine, Inc. Reproduction of this drawing in any form, in whole or in part, including transmissions of any type, to third parties is forbidden without the prior written consent of Response Marine, Inc.

REV.	DESCRIPTION

Eng. Girder Flanges & Frames		
40' Jet Cruiser- Setz		
SCALE 3/4"=1'	DES/DWN WAL	DATE 2/1/19
Response Marine, Inc.		REV
Newburyport, MA, www.responsemarine.com		DWG. NO. 585-2-3

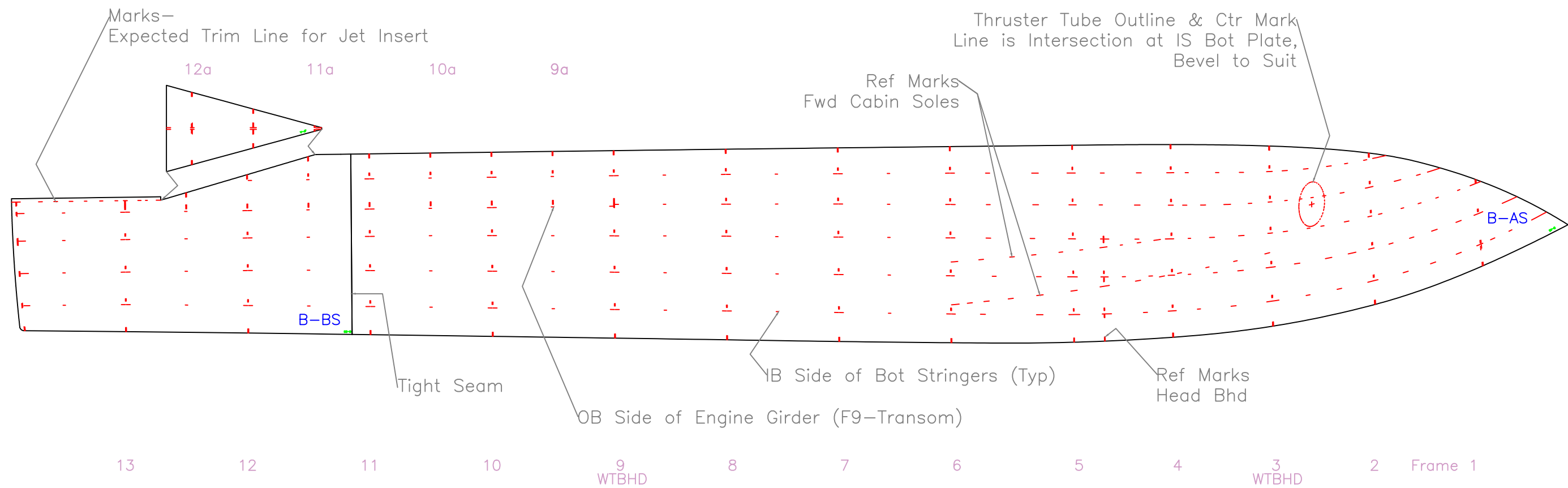

This drawing represents significant intellectual property of Response Marine, Inc. Reproduction of this drawing in any form, in whole or in part, including transmissions of any type, to third parties is forbidden without the prior written consent of Response Marine, Inc.

REV.	DESCRIPTION

BOTTOM PLATE LAYOUT		
40' Jet Cruiser- Setz		
SCALE 3/8"=1'	DES/DWN WAL	DATE 2/1/19
Response Marine, Inc.		REV.
Newburyport, MA, www.responsemarine.com		DWG. NO. 585-2-4

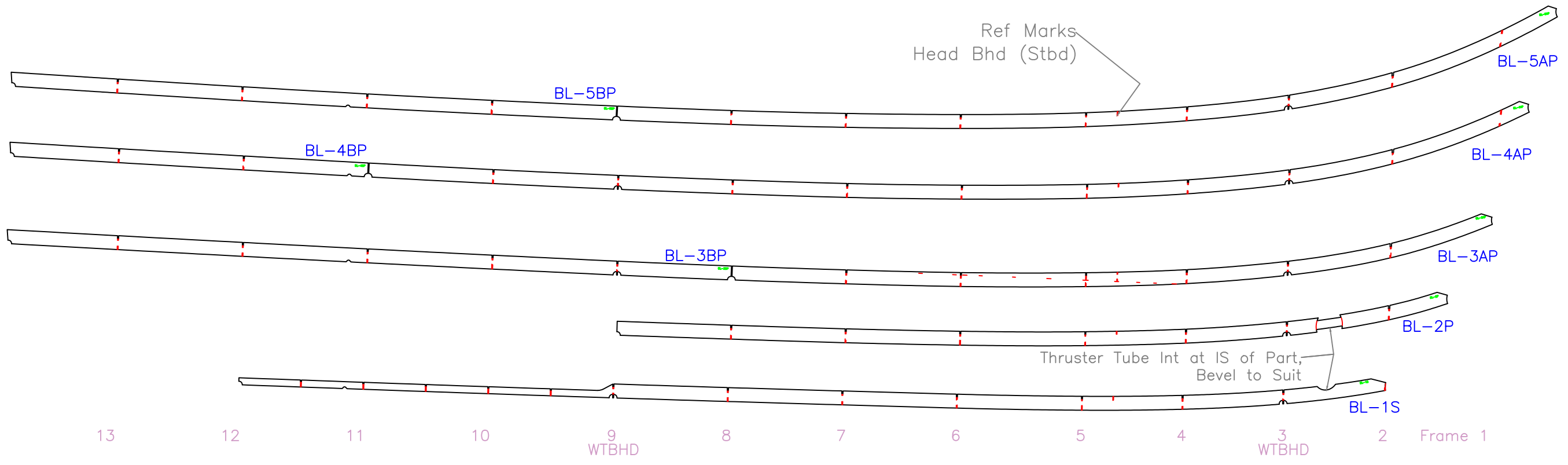

This drawing represents significant intellectual property of Response Marine, Inc. Reproduction of this drawing in any form, in whole or in part, including transmissions of any type, to third parties is forbidden without the prior written consent of Response Marine, Inc.

REV.	DESCRIPTION

BOTTOM STRINGERS		
40' Jet Cruiser- Setz		
SCALE 3/8"=1'	DES/DWN WAL	DATE 2/1/19
Response Marine, Inc.		REV
Newburyport, MA, www.responsemarine.com		DWG NO. 585-2-5

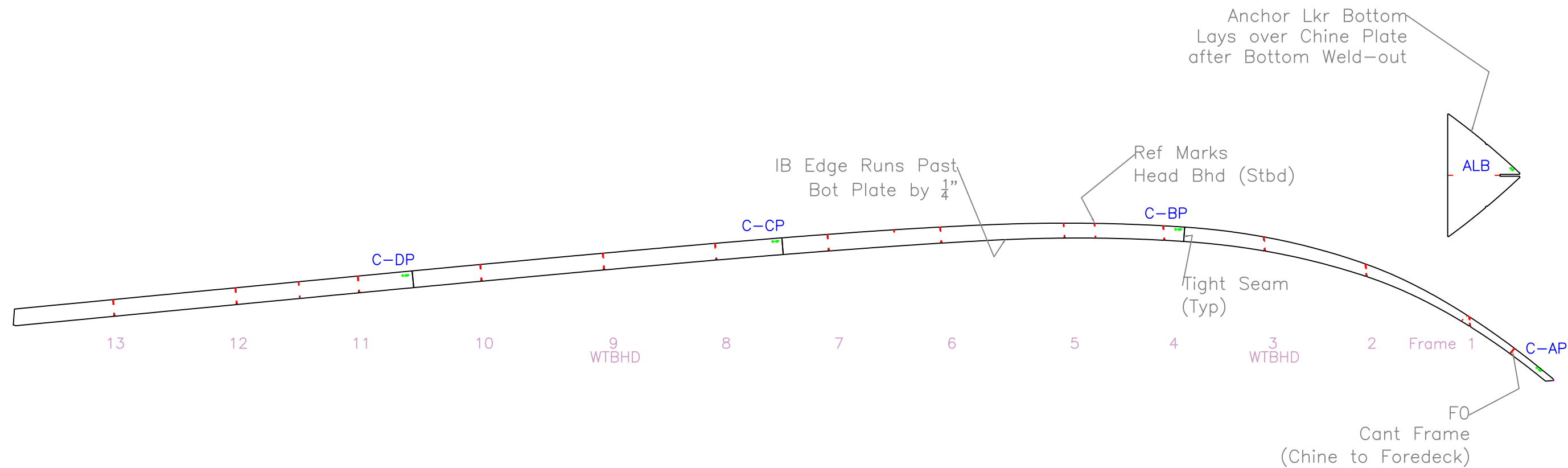

This drawing represents significant intellectual property of Response Marine, Inc. Reproduction of this drawing in any form, in whole or in part, including transmissions of any type, to third parties is forbidden without the prior written consent of Response Marine, Inc.

REV.	DESCRIPTION

CHINE LAYOUT		
40' Jet Cruiser- Setz		
SCALE 3/8"=1'	DES/DWN WAL	DATE 2/1/19
Response Marine, Inc.		REV.
Newburyport, MA, www.responsemarine.com		DWG. NO. 585-2-6

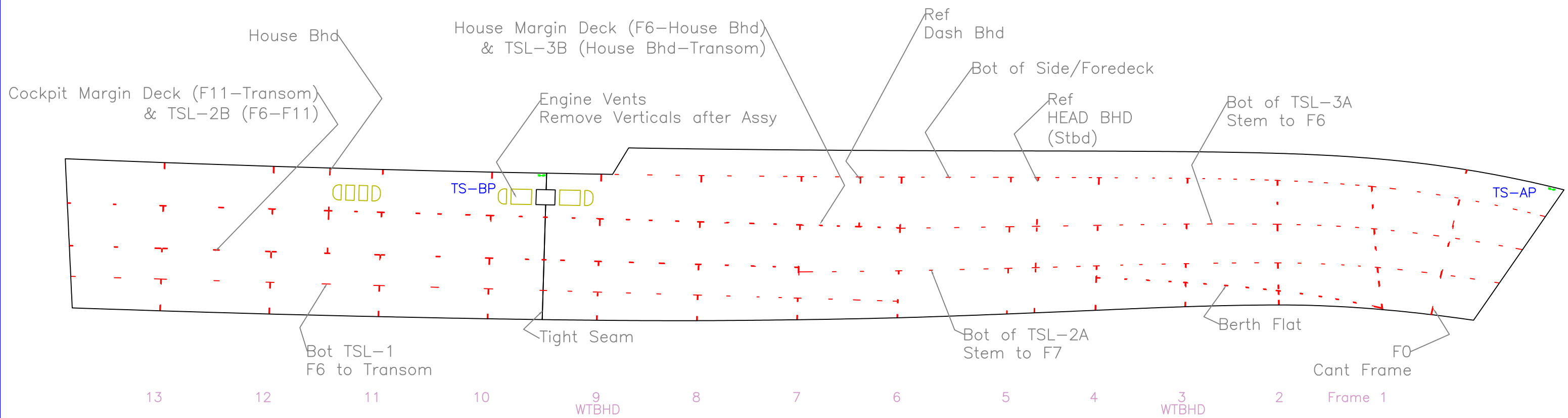

This drawing represents significant intellectual property of Response Marine, Inc. Reproduction of this drawing in any form, in whole or in part, including transmissions of any type, to third parties is forbidden without the prior written consent of Response Marine, Inc.

REV.	DESCRIPTION

TOPSIDE PLATE LAYOUT		
40' Jet Cruiser- Setz		
SCALE 3/8"=1'	DES/DWN WAL	DATE 2/1/19
Response Marine, Inc.		REV
Newburyport, MA, www.responsemarine.com		DWG NO. 585-2-7

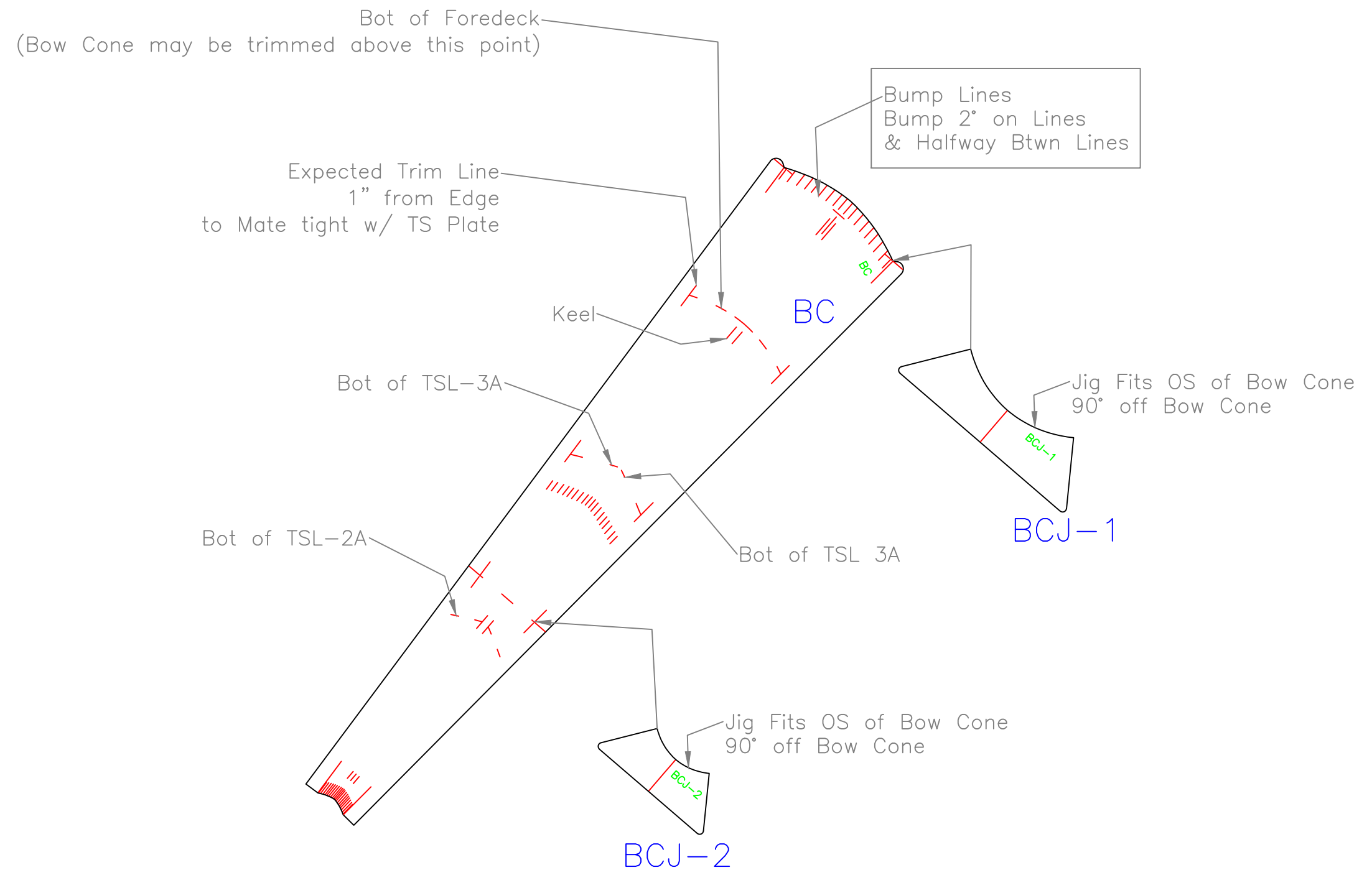

This drawing represents significant intellectual property of Response Marine, Inc. Reproduction of this drawing in any form, in whole or in part, including transmissions of any type, to third parties is forbidden without the prior written consent of Response Marine, Inc.

REV.	DESCRIPTION

BOW CONE		
40' Jet Cruiser- Setz		
SCALE 1 1/2"=1'	DES/DWN WAL	DATE 2/1/19
Response Marine, Inc.		REV
Newburyport, MA, www.responsemarine.com		DWG NO. 585-2-8

Jigs Fit IS or OS Transom
OS is preferred

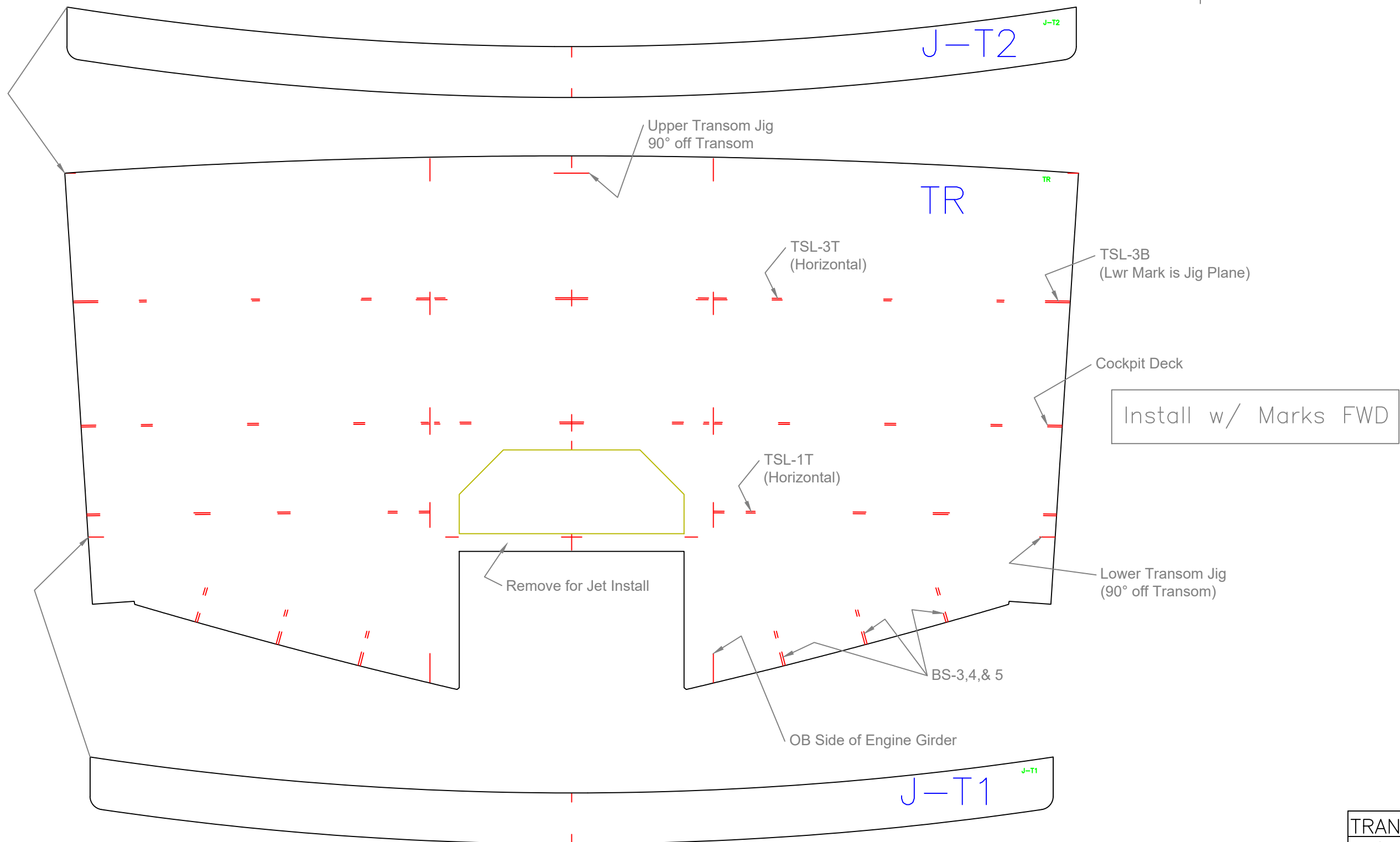

This drawing represents significant intellectual property of Response Marine, Inc. Reproduction of this drawing in any form, in whole or in part, including transmissions of any type, to third parties is forbidden without the prior written consent of Response Marine, Inc.

REV.	DESCRIPTION

TRANSOM		
40' Jet Cruiser- Setz		
SCALE 1"=1'	DES/DWN WAL	DATE 2/1/19
Response Marine, Inc.		REV
Newburyport, MA, www.responsemarine.com		DWG. NO. 585-2-9

Foredeck Camber Jig, Transverse Fits on Top, 3" Fwd of F2

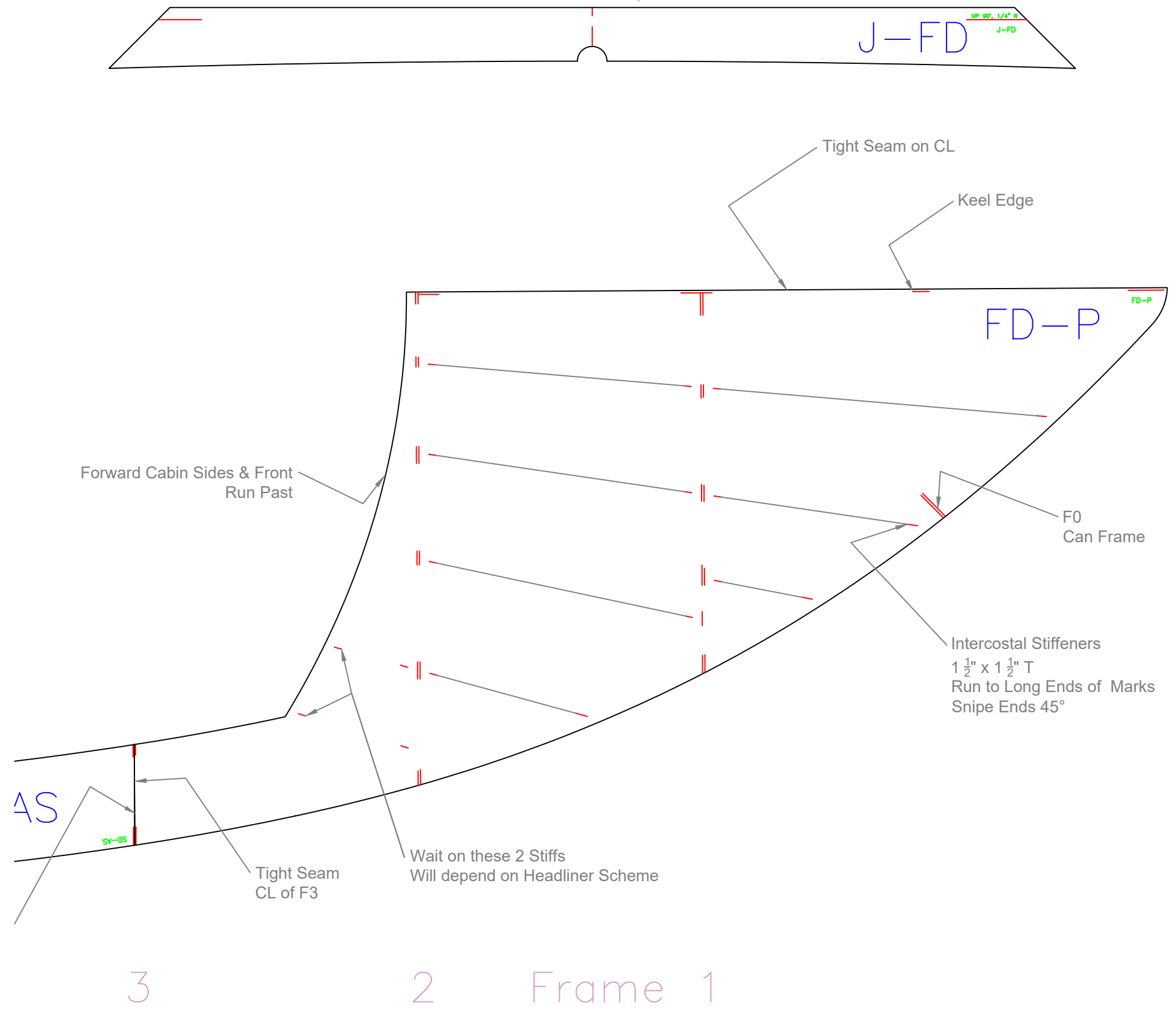

This drawing represents significant intellectual property of Response Marine, Inc. Reproduction of this drawing in any form, in whole or in part, including transmissions of any type, to third parties is forbidden without the prior written consent of Response Marine, Inc.

REV.	DESCRIPTION

FOREDECK		
40' Jet Cruiser- Setz		
SCALE 1"=1'	DES/DWN WAL	DATE 2/1/19
Response Marine, Inc.		REV
Newburyport, MA, www.responsemarine.com		DWG NO. 585-2-10

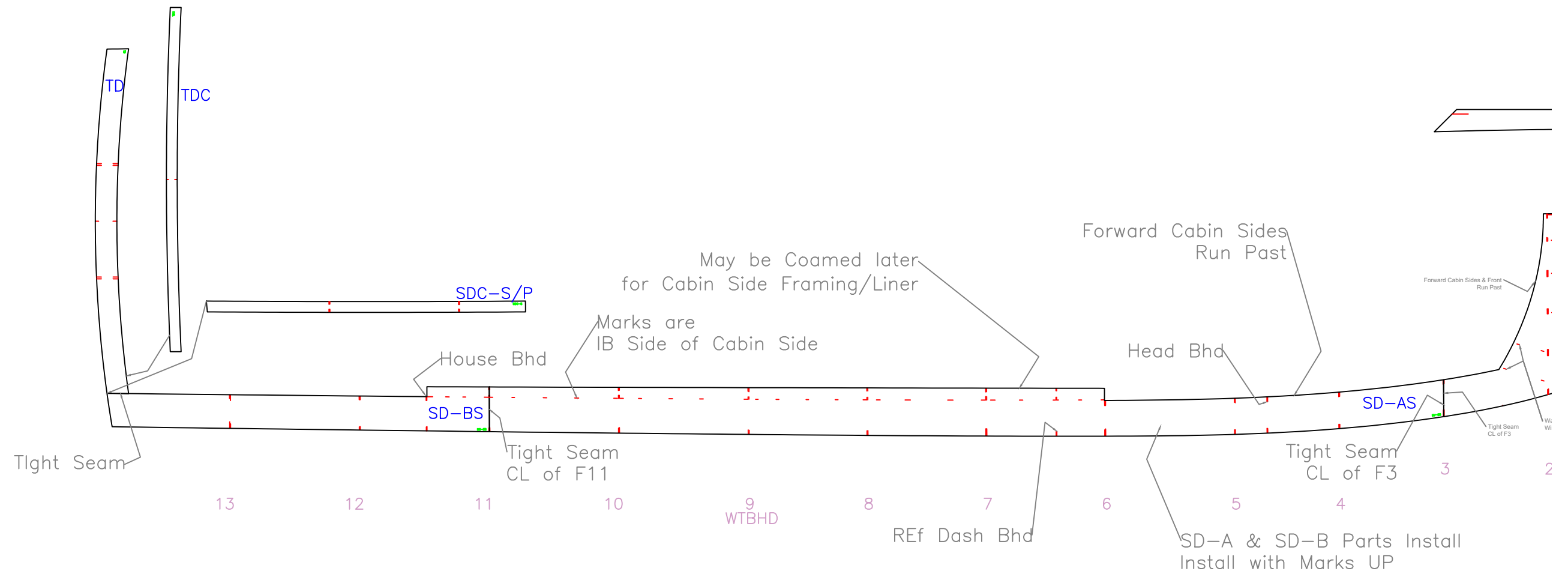

This drawing represents significant intellectual property of Response Marine, Inc. Reproduction of this drawing in any form, in whole or in part, including transmissions of any type, to third parties is forbidden without the prior written consent of Response Marine, Inc.

REV.	DESCRIPTION

SIDE DECKS		
40' Jet Cruiser- Setz		
SCALE 3/8"=1'	DES/DWN WAL	DATE 2/1/19
Response Marine, Inc.		REV
Newburyport, MA, www.responsemarine.com		DWG. NO. 585-2-11

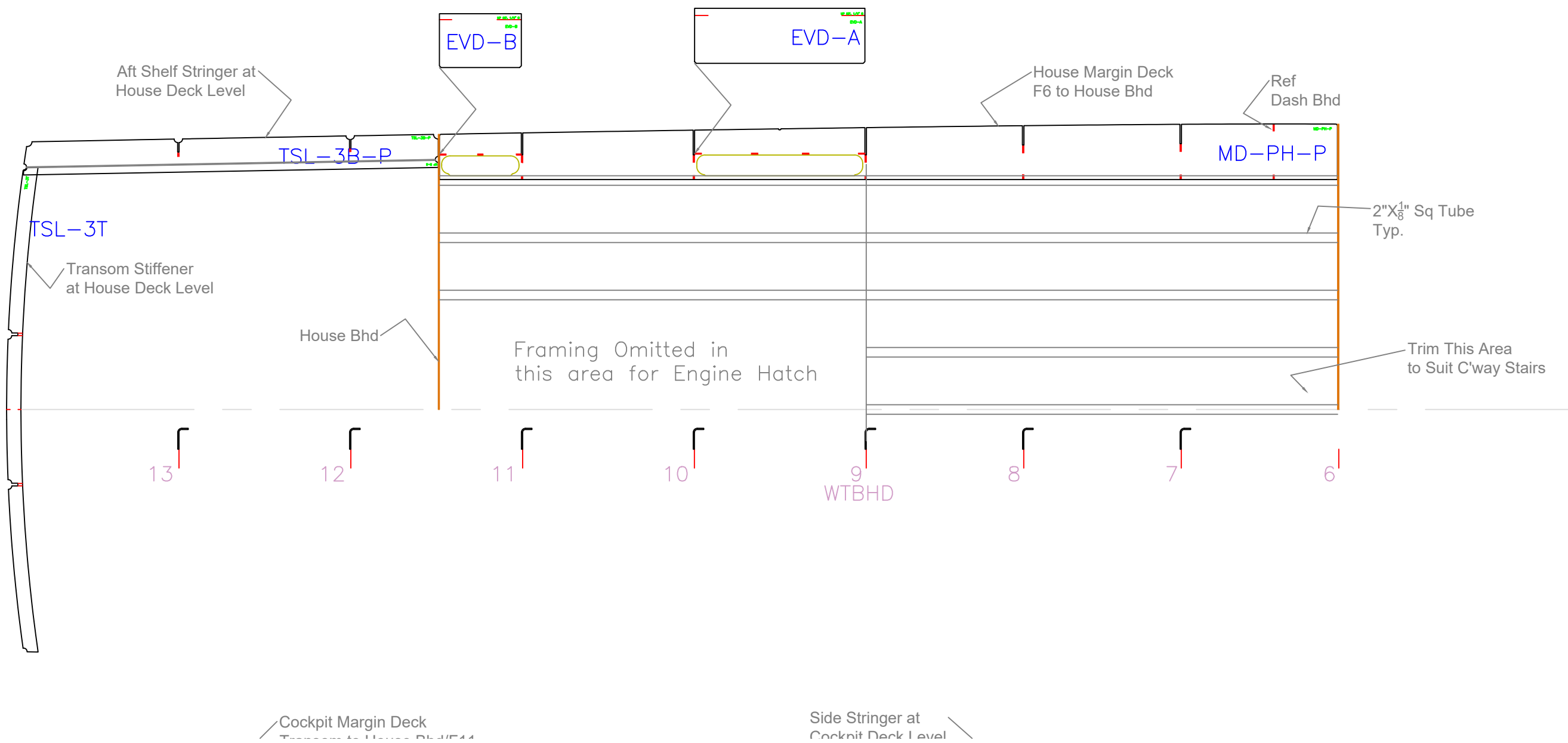

This drawing represents significant intellectual property of Response Marine, Inc. Reproduction of this drawing in any form, in whole or in part, including transmissions of any type, to third parties is forbidden without the prior written consent of Response Marine, Inc.

REV.	DESCRIPTION

PILOTHOUSE DECK		
40' Jet Cruiser- Setz		
SCALE 1/2"=1'	DES/DWN WAL	DATE 2/1/19
Response Marine, Inc.		REV
Newburyport, MA, www.responsemarine.com		DWG. NO. 585-2-12

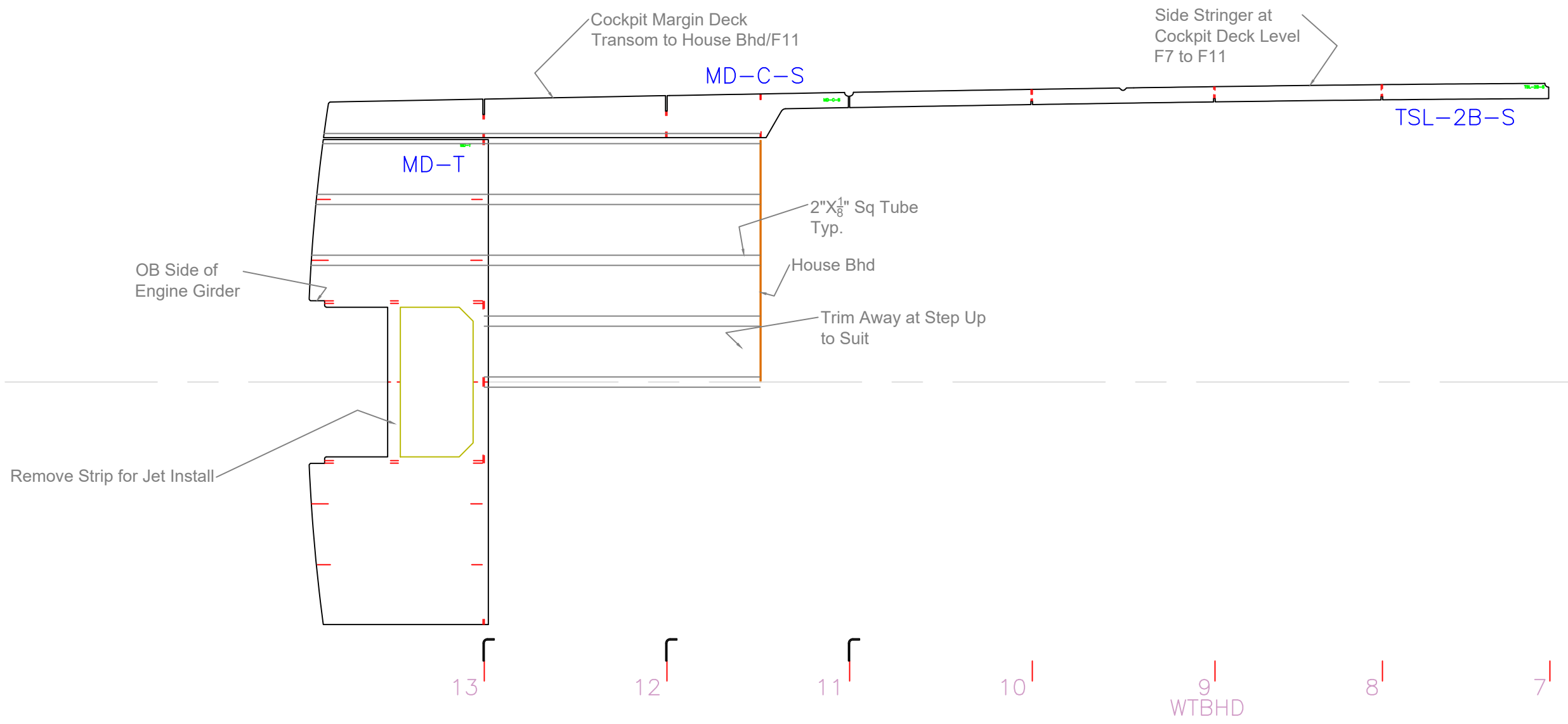

This drawing represents significant intellectual property of Response Marine, Inc. Reproduction of this drawing in any form, in whole or in part, including transmissions of any type, to third parties is forbidden without the prior written consent of Response Marine, Inc.

REV.	DESCRIPTION

COCKPIT DECK		
40' Jet Cruiser- Setz		
SCALE 1/2"=1'	DES/DWN WAL	DATE 2/1/19
Response Marine, Inc.		REV.
Newburyport, MA, www.responsemarine.com		DWG. NO. 585-2-13

Vee Berth
Footwell

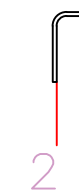
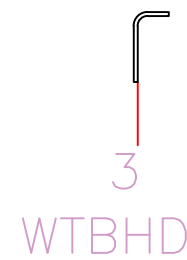
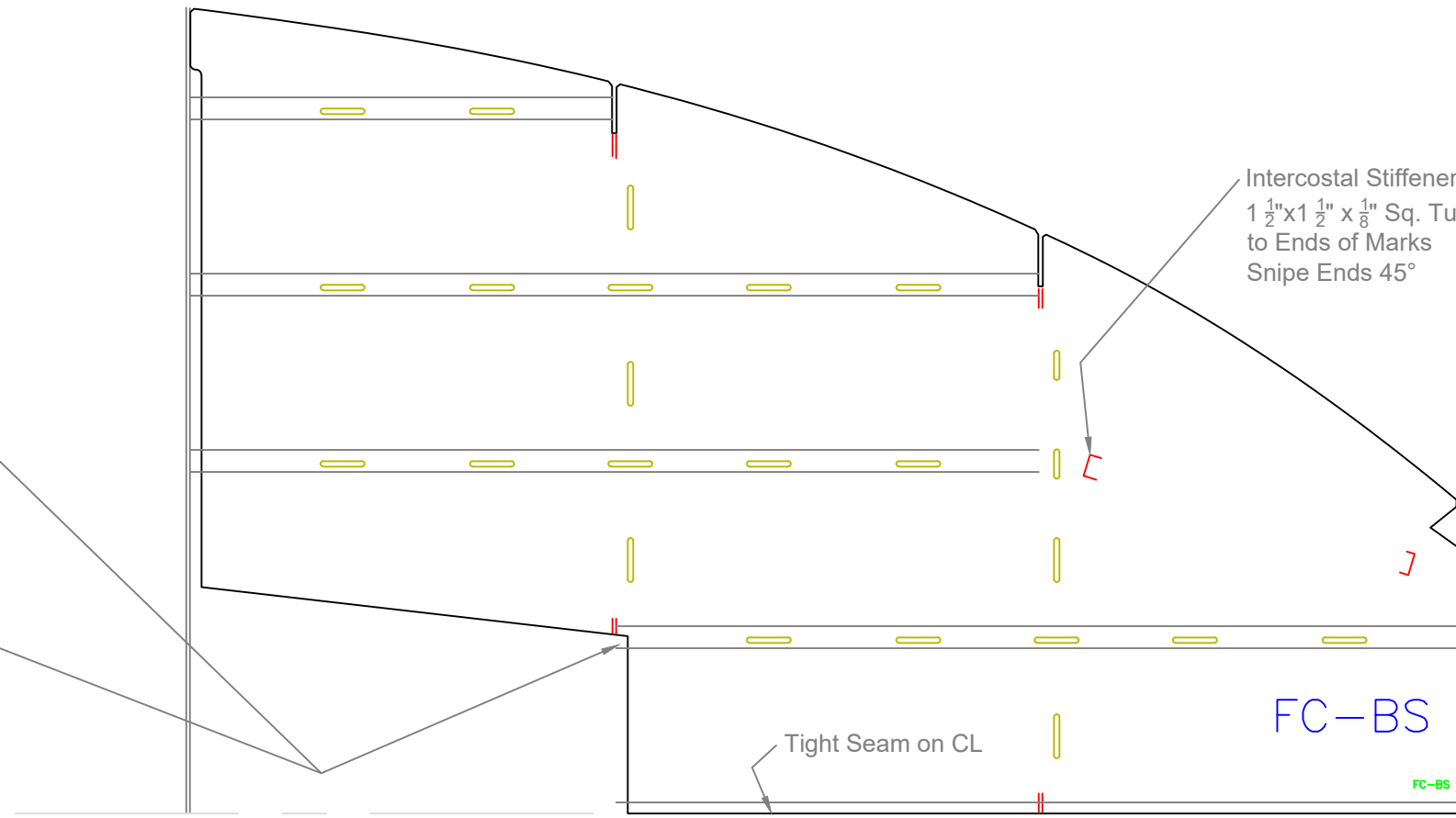
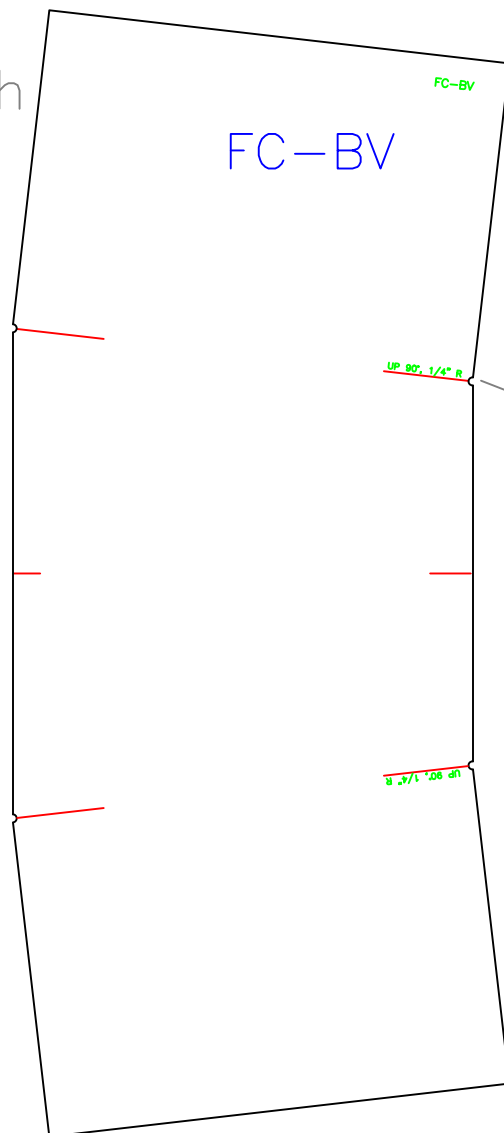

This drawing represents significant intellectual property of Response Marine, Inc. Reproduction of this drawing in any form, in whole or in part, including transmissions of any type, to third parties is forbidden without the prior written consent of Response Marine, Inc.

REV.	DESCRIPTION

Fwd Cabin Vee Berth		
40' Jet Cruiser- Setz		
SCALE 3/4"=1'	DES/DWN WAL	DATE 2/1/19
Response Marine, Inc.		REV
Newburyport, MA, www.responsemarine.com		DWG. NO. 585-2-14

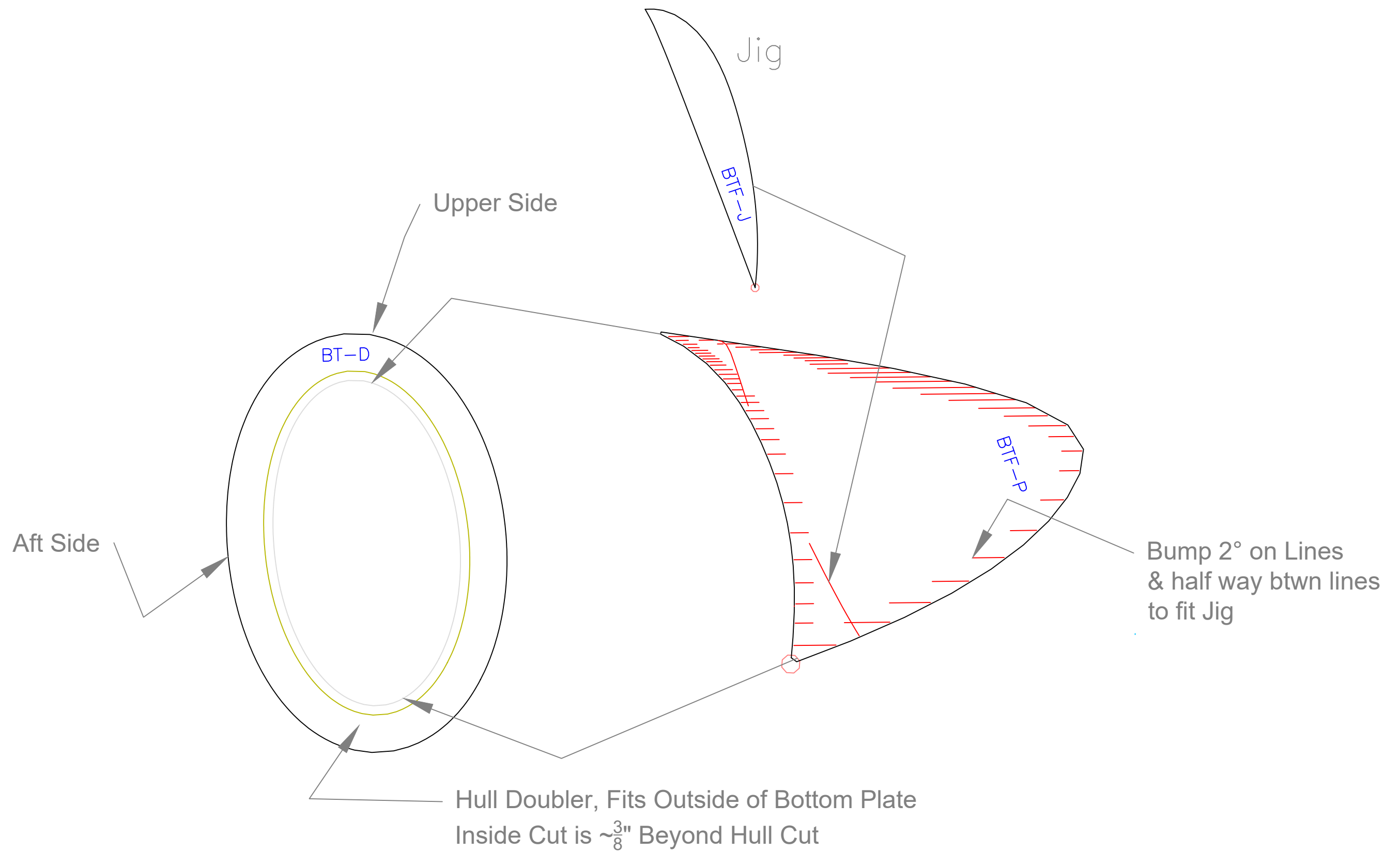

This drawing represents significant intellectual property of Response Marine, Inc. Reproduction of this drawing in any form, in whole or in part, including transmissions of any type, to third parties is forbidden without the prior written consent of Response Marine, Inc.

REV.	DESCRIPTION

Bow Thruster Dblr & Fairing		
40' Jet Cruiser- Setz		
SCALE 3"=1'	DES/DWN WAL	DATE 2/1/19
Response Marine, Inc.		REV.
Newburyport, MA, www.responsemarine.com		DWG. NO. 585-2-15

Chine Detail
Full Scale

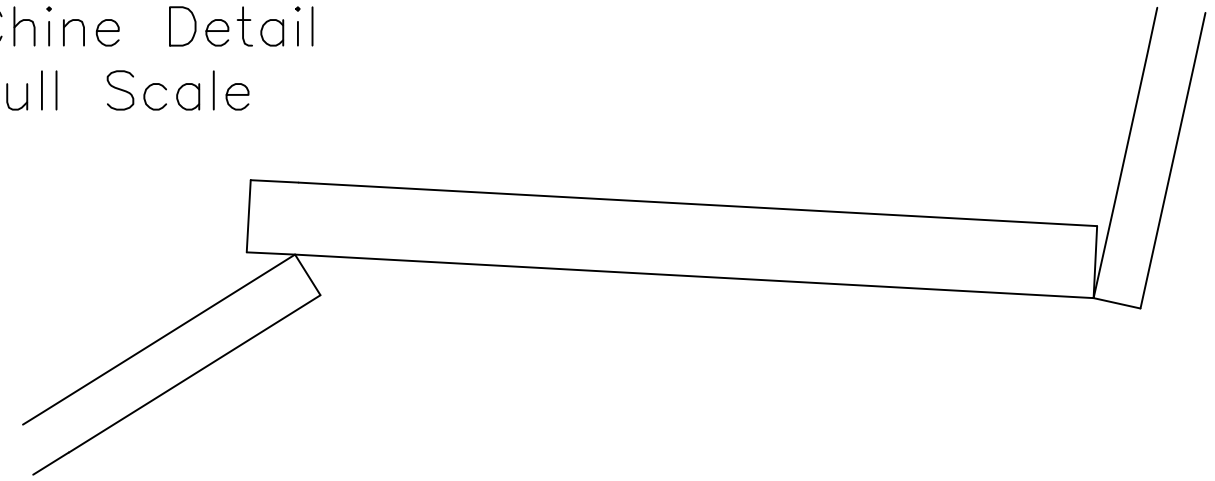

Open Cnr

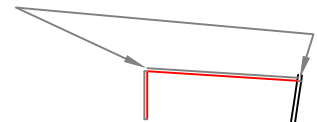

Keel Detail
Full Scale

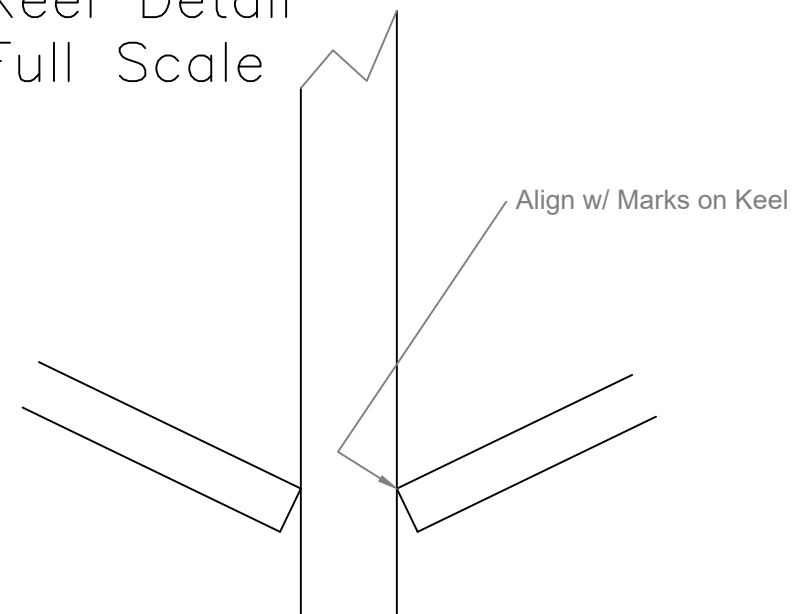

Frame Vertical alignment
w/ corresponding marks on Keel

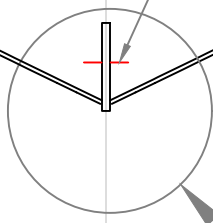

This drawing represents significant intellectual property of Response Marine, Inc. Reproduction of this drawing in any form, in whole or in part, including transmissions of any type, to third parties is forbidden without the prior written consent of Response Marine, Inc.

REV. DESCRIPTION

FORMING- FLANGE "B-1"		
40' Jet Cruiser- Setz		
SCALE as noted	DES/DWN WAL	DATE 2/1/19
Response Marine, Inc.		REV.
Newburyport, MA, www.responsemarine.com		DWG. NO. 585-CR-1

STANDARD FLANGE "B-1" BENDING: $\frac{1}{4}$ " 5086/83 H116 Stock

- 1) Confirm results for dimensions and cracking with test strips before bending frames.
- 2) Expected Die Radius is $\frac{5}{8}$ "
- 3) Flanges are designed for outside major flange length of $1\frac{5}{8}$ " less than flat stock length as shown.
- 4) Expected Back Gauge setting is 1.91", but confirm and adjust, based on test strip.

Parts to be flanged per this same set-up are listed at left.

F3	Frame 3, Body
F3-P	Frame 3, Upper Port
F3-S	Frame 3, Upper Stbd
F2	Frame 2, Body
F2-P	Frame 2, Upper Port
F2-S	Frame 2, Upper Stbd
F4	Frame 4, Body
F4-P	Frame 4, Upper Port
F4-S	Frame 4, Upper Stbd
F7	Frame 7, Body
F8	Frame 8, Body
F9	Frame 9, WT BHD, Body
F11	Frame 11, Body
F10	Frame 10, Body
F12	Frame 12, Body
F13	Frame 13, Body

16 Parts

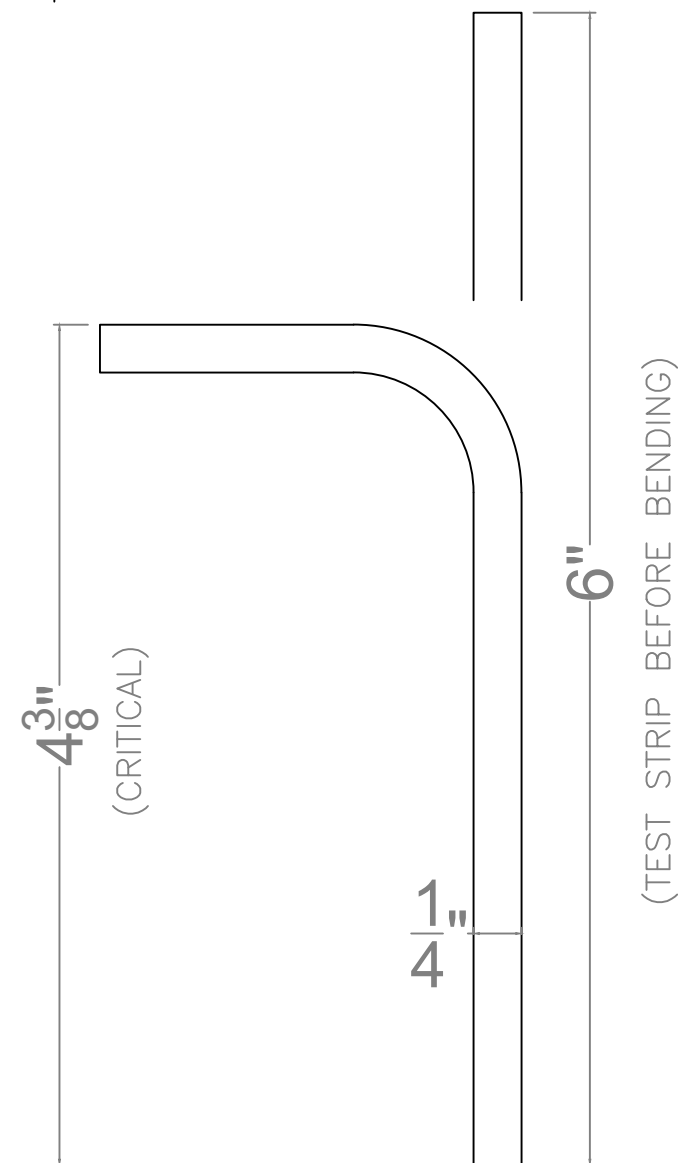

FORMING- FLANGE "B-1"		
40' Jet Cruiser- Setz		
SCALE 3/4"=1'	DES/DWN WAL	DATE 1/28/19
REV		DWG. NO. 585-B-1
Response Marine, Inc.		
Newburyport, MA, www.responsemarine.com		

REV.	DESCRIPTION

STANDARD FLANGE "B-2" BENDING: $\frac{3}{16}$ " 5086/83 H116 Stock

- 1) Confirm results for dimensions and cracking with test strips before bending frames.
- 2) Expected Die Radius is $\frac{1}{2}$ "
- 3) Flanges are designed for outside major flange length of $1\frac{1}{2}$ " less than flat stock length as shown.
- 4) Expected Back Gauge setting is 1.72", but confirm and adjust, based on test strip.

Parts to be flanged per this same set-up are listed at left.

- F5-P Frame 5, Port Bhd
- F5-S Frame 5, Stbd
- H-BHD Head Bulkhead
- TSL-3B-P Topside Longitudinal 3, PH Bhd to Transom, Port
- TSL-3B-S Topside Longitudinal 3, PH Bhd to Transom, Stbd

5 Parts

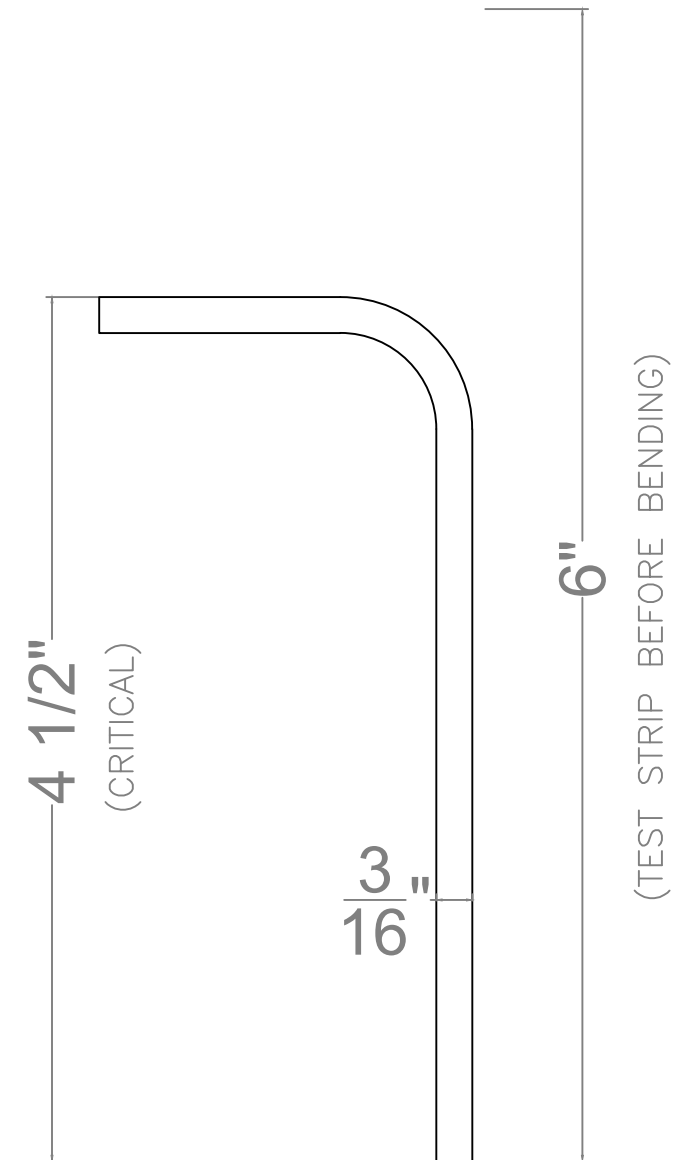

FORMING- FLANGE "B-2"		
40' Jet Cruiser- Setz		
SCALE $\frac{3}{4}$ "=1'	DES/DWN WAL	DATE 1/28/19
Response Marine, Inc. Newburyport, MA, www.responsemarine.com		REV DWG. NO. 585-B-2

REV. DESCRIPTION

L'kg Aft
 Install with Marks & Formed
 Flanges FWD
 (Flanges shown before forming)

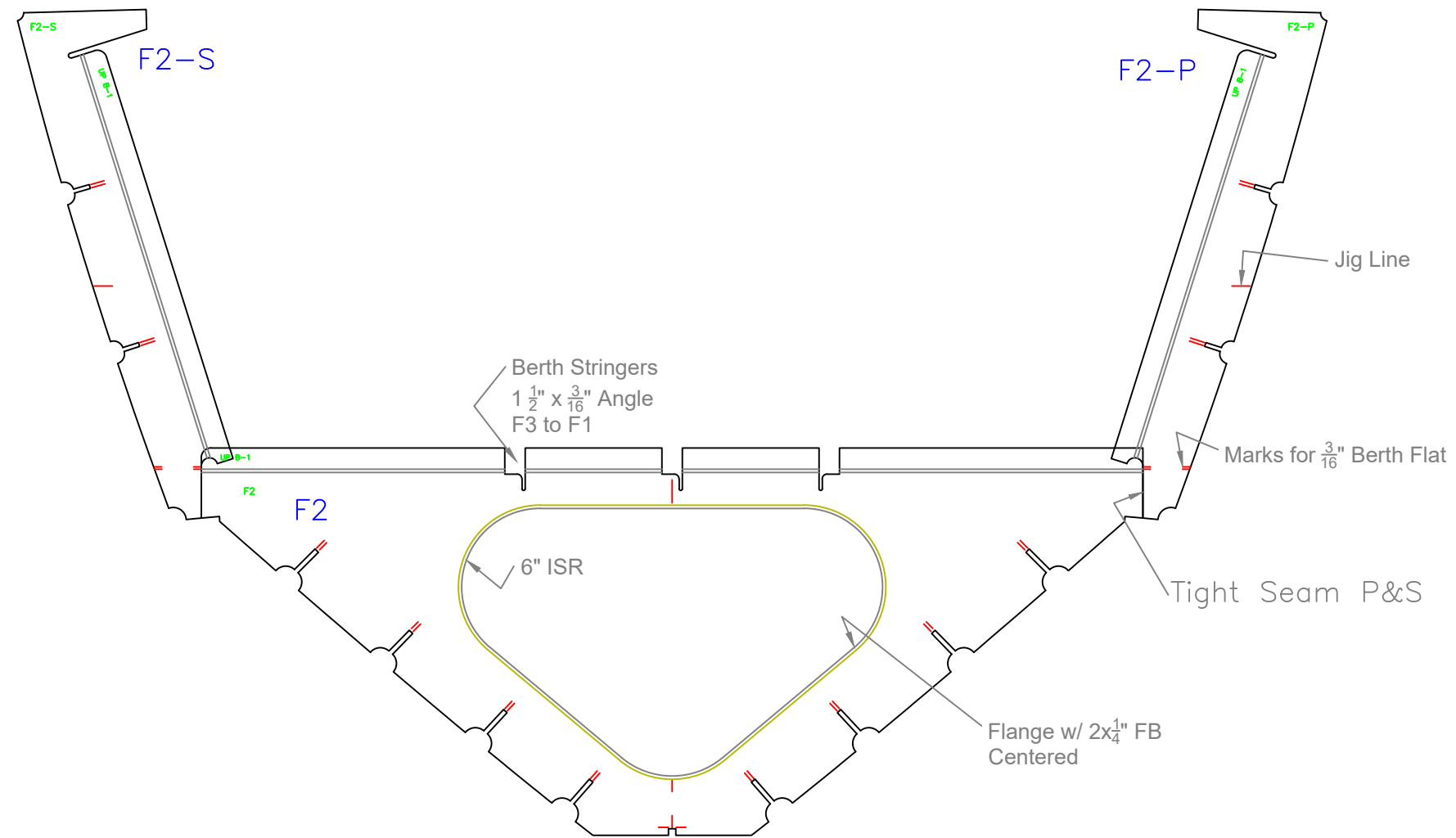

This drawing represents significant intellectual property of Response Marine, Inc. Reproduction of this drawing in any form, in whole or in part, including transmissions of any type, to third parties is forbidden without the prior written consent of Response Marine, Inc.

REV.	DESCRIPTION

Frame 2		
40' Jet Cruiser-Setz		
SCALE 1"=1'	DES/DWN WAL	DATE 1/29/19
Response Marine, Inc.		REV
Newburyport, MA, www.responsemarine.com		DWG. NO. 585-F2

L'kg Fwd
 Install with Marks & Formed
 Flange AFT
 (Flange shown before forming)

Install AFTER Hull Plating

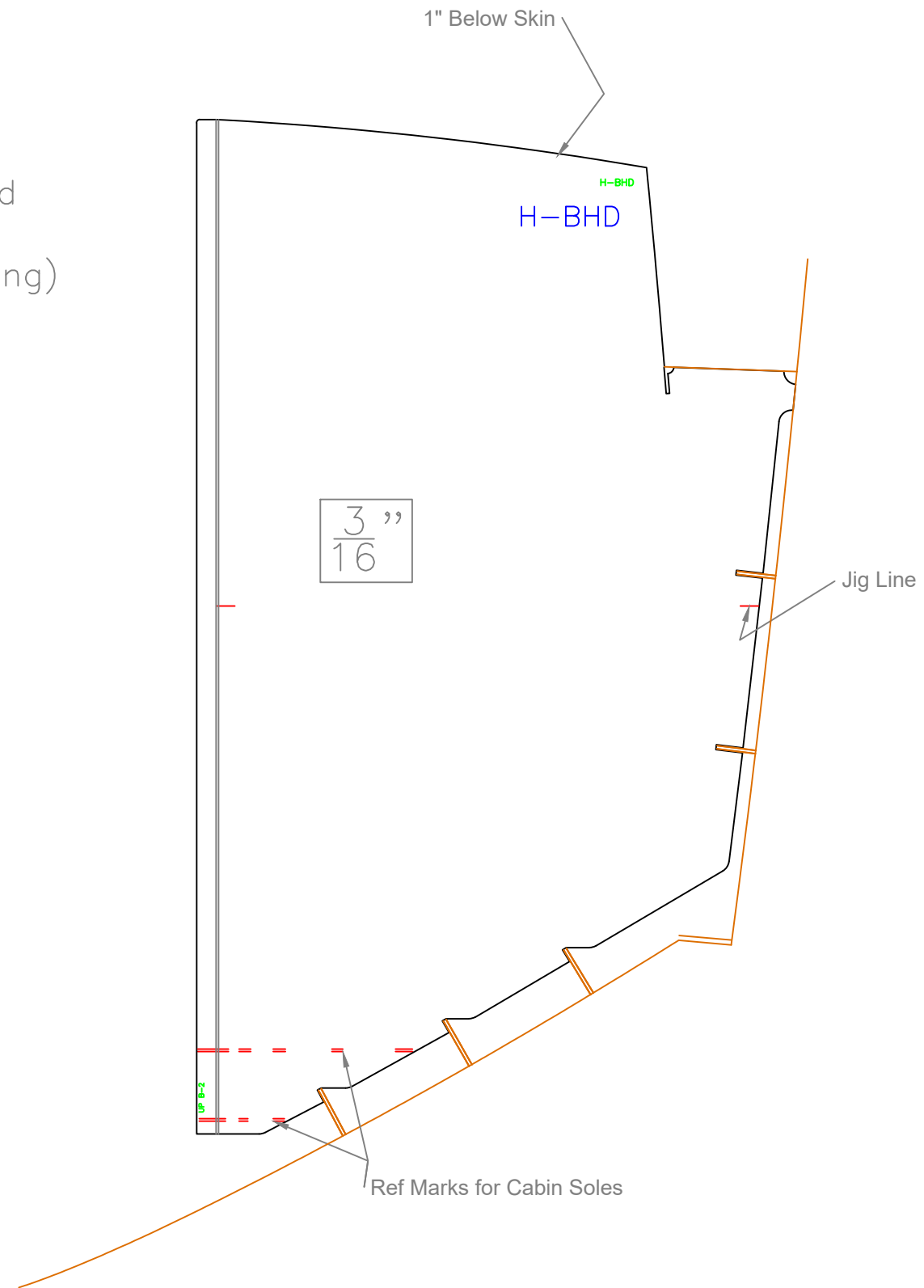

This drawing represents significant intellectual property of Response Marine, Inc. Reproduction of this drawing in any form, in whole or in part, including transmissions of any type, to third parties is forbidden without the prior written consent of Response Marine, Inc.

REV.	DESCRIPTION

HEAD BULKHEAD		
40' Jet Cruiser- Setz		
SCALE 1"=1'	DES/DWN WAL	DATE 1/29/19
Response Marine, Inc.		REV
Newburyport, MA, www.responsemarine.com		DWG. NO. 585-F4a

L'kg Aft
 Install with Marks FWD
 & Stiffeners AFT

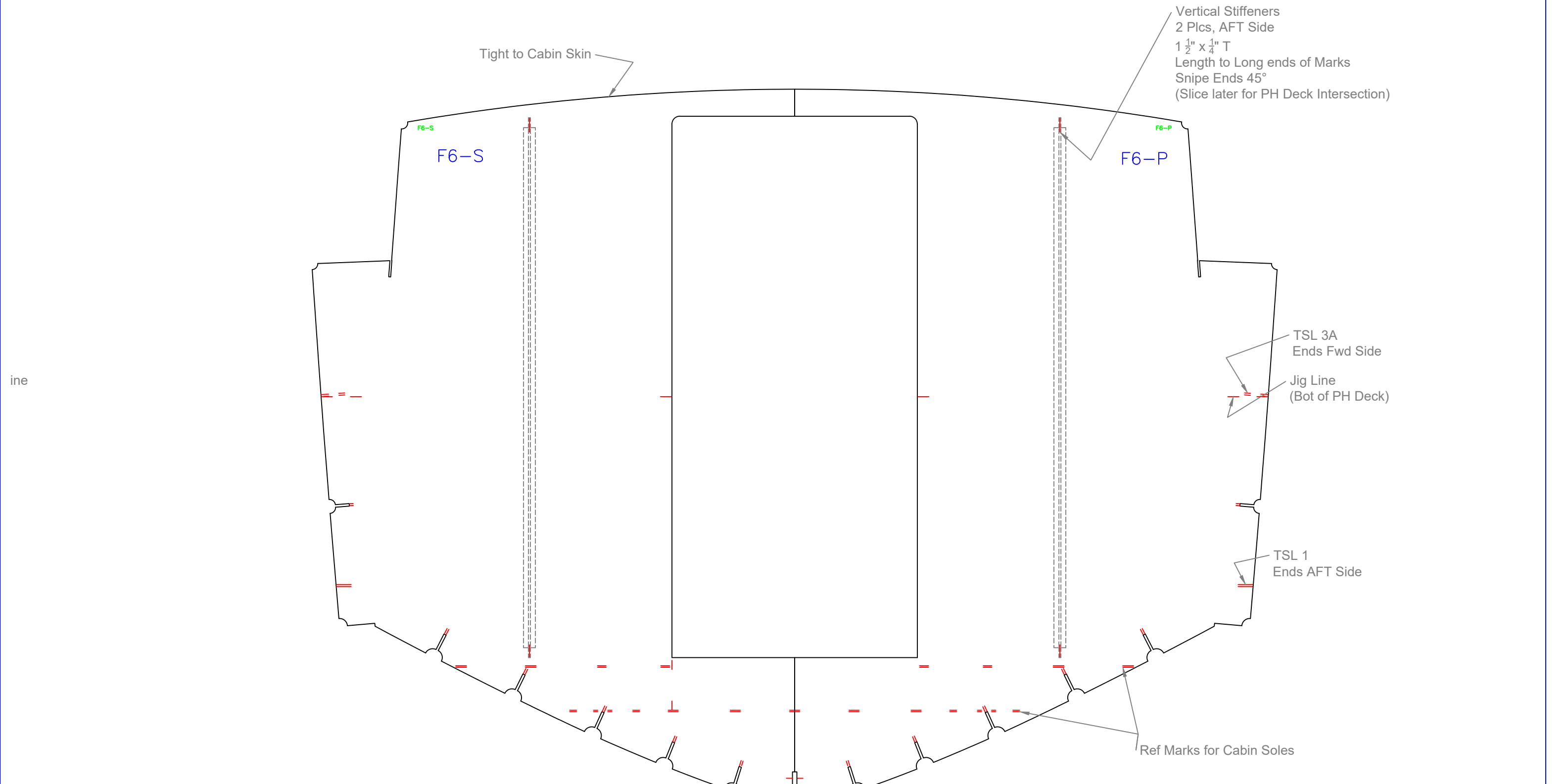

ine

This drawing represents significant intellectual property of Response Marine, Inc. Reproduction of this drawing in any form, in whole or in part, including transmissions of any type, to third parties is forbidden without the prior written consent of Response Marine, Inc.

REV.	DESCRIPTION

Frame 6		
40' Jet Cruiser-Setz		
SCALE 1"=1'	DES/DWN WAL	DATE 1/29/19
Response Marine, Inc.		REV
Newburyport, MA, www.responsemarine.com		DWG NO. 585-F6

L'kg Fwd
 Install with Marks & Formed
 Flanges FWD
 (Flanges shown before forming)

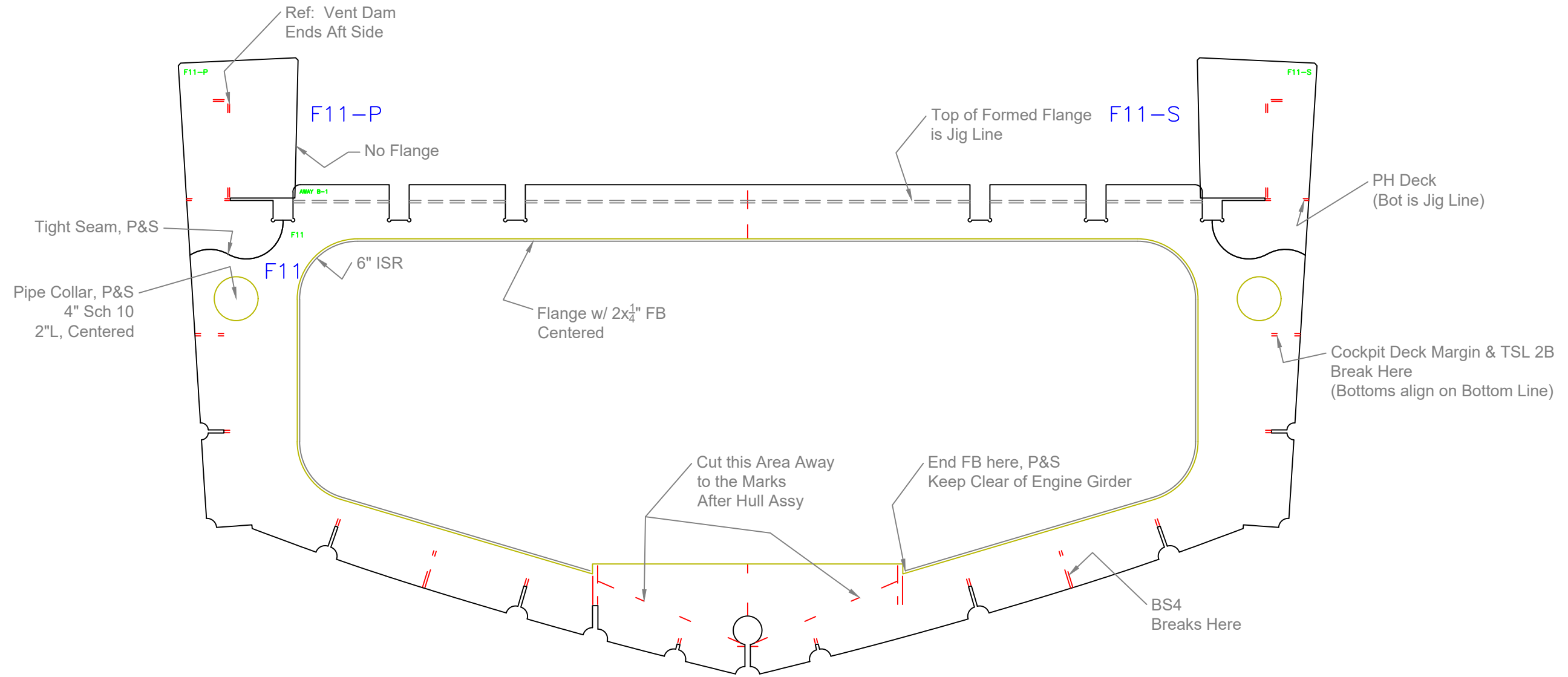

This drawing represents significant intellectual property of Response Marine, Inc. Reproduction of this drawing in any form, in whole or in part, including transmissions of any type, to third parties is forbidden without the prior written consent of Response Marine, Inc.

REV.	DESCRIPTION

Frame 11		
40' Jet Cruiser-Setz		
SCALE 1"=1'	DES/DWN WAL	DATE 1/29/19
Response Marine, Inc.		REV
Newburyport, MA, www.responsemarine.com		DWG NO. 585-F11

L'kg Aft
 Install with Marks & Formed
 Flanges FWD
 (Flanges shown before forming)

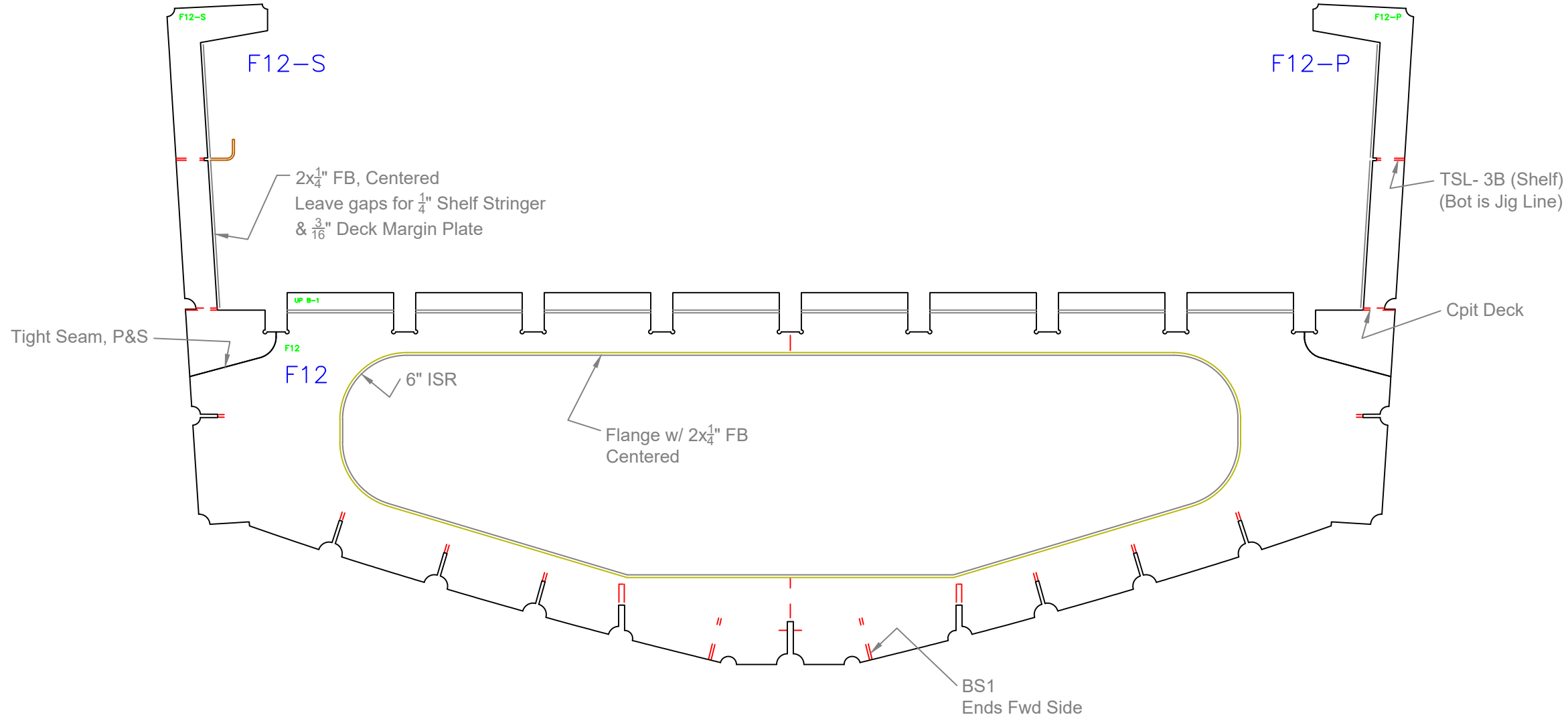

This drawing represents significant intellectual property of Response Marine, Inc. Reproduction of this drawing in any form, in whole or in part, including transmissions of any type, to third parties is forbidden without the prior written consent of Response Marine, Inc.

REV. DESCRIPTION

Frame 12		
40' Jet Cruiser- Setz		
SCALE 1"=1'	DES/DWN WAL	DATE 1/29/19
Response Marine, Inc.		REV
Newburyport, MA, www.responsemarine.com		DWG. NO. 585-F12